



EGI-Engage

Second version of enhanced portal for EISCAT_3D

D6.21

Date	18/Jul/2017
Activity	SA2
Lead Partner	EISCAT
Document Status	FINAL
Document Link	

Abstract

This report was produced by the EISCAT_3D Competence Centre of the EGI-Engage H2020 project.

EISCAT_3D is an environmental research infrastructure project on the ESFRI (European Strategy Forum on Research Infrastructures) roadmap. Once assembled, it will be a world-leading international research infrastructure to study the atmosphere in the Fenno-Scandinavian Arctic and to investigate how the Earth's atmosphere is coupled to space. Researchers will be able to interact with EISCAT_3D data through a user portal. This portal should provide a web-based user interface for searching, retrieval and re-processing (visualisation, analysis) of EISCAT_3D data.

This document describes the envisaged role of the user portal and its relation to the suggested EISCAT_3D data model, based on experience of DIRAC-based prototype implementation. This implementation is running in the framework of DIRAC4EGI and has been developed, tested and debugged by the EGI-Engage EISCAT_3D Competence Centre, with assistance from the broader EISCAT user community. Important issues that still need to be clarified during future portal developments have been identified.

COPYRIGHT NOTICE



This work by Parties of the EGI-Engage Consortium is licensed under a Creative Commons Attribution 4.0 International License (<http://creativecommons.org/licenses/by/4.0/>). The EGI-Engage project is co-funded by the European Union Horizon 2020 programme under grant number 654142.

DELIVERY SLIP

	<i>Name</i>	<i>Partner/Activity</i>	<i>Date</i>
From:	Ingemar Häggström	EISCAT	18/Jul/2017
Moderated by:	Małgorzata Krakowian	EGI.eu/WP1	
Reviewed by	Andrei Tsaregorodtsev Matthew Viljoen Kostas Koumantaros	CNRS / WP6 EGI.eu / Data TCB Chair GRNET/ EGI Engage PMB	
Approved by:			

DOCUMENT LOG

<i>Issue</i>	<i>Date</i>	<i>Comment</i>	<i>Author/Partner</i>
v.1	24 May 2017	First draft for external review	Ingemar Häggström/EISCAT Carl-Fredrik Enell/EISCAT With various inputs from members of the EISCAT_3D CC: (https://wiki.egi.eu/wiki/CC-EISCAT_3D)
FINAL	18 Jul 2017	Ready for submission	

TERMINOLOGY

A complete project glossary is provided at the following page: <http://www.egi.eu/about/glossary/>

Contents

Executive summary.....	4
1 Introduction.....	6
2 Service architecture.....	7
2.1 High-Level Service architecture	8
2.2 Data used in the prototype portal	9
2.3 Data access	10
2.4 Community Policy based File access.....	10
2.5 User Request Workflow.....	11
2.6 Portal interfaces.....	12
3 EISCAT-3D Data Management.....	16
3.1 Data levels	16
3.2 Data Model and metadata catalogues.....	18
3.3 Data Formats	21
3.4 Data catalogue schemas	22
4 Data Analysis	23
4.1 Visualisation.....	23
4.2 Lagprofiling	23
4.3 Lagprofiler code and DIRAC	23
5 Plan for Exploitation and Dissemination	24
6 Future Plans.....	26
6.1 Scientific and technical use cases	26
6.2 Services and resources	28
7. References	29
Appendix A: EISCAT Portal User Guide	31
A.1 Introduction	31
A.1.1 DIRAC.....	31
A.1.2 Layout of the EISCAT DIRAC service	31
A.2 Getting access to the DIRAC portal	32
A.3 Searching EISCAT data	37
A.3.1 Basic search	38
A.4 Downloading EISCAT data	39
A.5 RTG plotting of EISCAT data files	40
A.6 Feedback.....	43
Appendix B: EISCAT Portal Administrator Guide	43
Appendix C: EISCAT-DIRAC software extension.....	43

Executive summary

EISCAT_3D will be a world-leading international research infrastructure using the incoherent scatter technique to study the upper atmosphere in the Fenno-Scandinavian Arctic, including how the Earth's atmosphere is coupled to space. The scientific applications also include space weather, plasma physics, space debris and near-Earth object studies.

More specific, EISCAT_3D will be a phased-array radar system located in Northern Fenno-Scandinavia near space research centres in Kiruna (Sweden), Sodankylä (Finland) and Tromsø (Norway), two rocket launch facilities at Andøya (Norway) and Esrange (Sweden), and several other distributed instrument networks for geospace observation (e.g. magnetometers and auroral cameras). EISCAT_3D will be operated by, and will be an integral part of, EISCAT Scientific Association. EISCAT has successfully operated incoherent scatter radars on the mainland and on Svalbard for more than 30 years. The current EISCAT Associates are China, Finland, Japan, Norway, Sweden, and the United Kingdom.

The EGI-Engage EISCAT_3D Competence Centre facilitates the setup of the EISCAT_3D system through developing a user portal. This portal will play a central role for the users of the EISCAT_3D system in a number of ways: it will provide services for researchers to discover, access and analyse (visualise, mine, etc.) data generated by EISCAT_3D.

This deliverable reports on the progress of portal development since the end of February 2016, when a similar deliverable, D6.3¹ was issued. D6.3 described the architecture setup and the first version of data structures and portal implementation. Since March 2016 the work progressed significantly in portal development using DIRAC service technology, and in collaboration with partner projects, particularly

- ENVRIplus - which produced the second version of the ENVRI reference model²,
- NeIC EISCAT_3D support project³ which detailed the EISCAT_3D needs in terms of data storage, network and computing,
- EISCAT_3D pilot in EUDAT⁴ which worked on workflow implementation.

As the data need to follow the EISCAT policy, defined in the statutes of EISCAT, some consideration on access and authentication still need to be investigated. This work will continue in the AARC2 project starting 1 June 2017, to enable fast development in this field.

This EGI-Engage deliverable describes the enhanced EISCAT portal. It now has a working access control and interfaces for data discovery and download as well as a function for analysis job

¹ EGI-Engage D6.3 Production portal for EISCAT_3D: <https://documents.egi.eu/document/2663>

² ENVRI Reference Model: <https://confluence.egi.eu/display/EC/ENVRI+Reference+Model>

³ Nordic e-Infrastructure Collaboration (NeIC) EISCAT_3D Support project: https://www.eiscat.se/business/projects/neic-eiscat_3d-support/

⁴ EISCAT Pilot in EUDAT: <https://www.eudat.eu/communities/unified-access-to-eiscat-radar-data>

submissions. The prototype demonstrator was used to facilitate the development of data models and modeling tools within the EISCAT_3D community, and the applicability of a central portal service can be used by scientists to interact and compute with EISCAT data. The deliverable comes with step-by-step Users Guide and a description for the portal administration. The EISCAT_3D data model has been developed to be able to fully describe the data but still be structured to suit storages in databases. The portal has been included in the recently submitted EOSC-hub initiative as one of the Competence Centre, where it will developed to be ready for the planned startup of EISCAT_3D in 2021.

1 Introduction

The design of the next generation incoherent scatter radar system, EISCAT_3D, opens up opportunities for physicists to explore many new research fields. On the other hand, it also introduces significant challenges in handling large-scale experimental data which will be massively generated at great speeds and volumes, the incoming speeds of about 4Tb/s need to be reduced to a few PB/year to be within operational funding limits. This challenge is typically referred to as a big data problem and requires solutions from beyond the capabilities of conventional database technologies.

The overall ambition of EISCAT_3D Competence Centre (EISCAT_3D CC) had been to provide the users of incoherent scatter radar with data analysis tools that improves opportunities for scientific discovery. The competence centre is also important for the build-up towards EISCAT_3D and the tools developed will form a base for further development.

With the development of a functional archive for the EISCAT data, this competence centre will make a foundation for new discoveries and significant scientific breakthroughs.

The EISCAT_3D CC develops a user portal. This portal is the point of access for researchers to discover, access and analyse (visualise, mine, etc.) data generated by EISCAT_3D. The portal allows refinements and further developments of the access of data. Important is also the training of the users, with valuable feedback, making the updated system ready for wider use. The system is also expected to lay a foundation for the development of a data archive for EISCAT_3D.

The CC opted to use the DIRAC interware <http://diracgrid.org/>, which is a mature system developed for the LHCb detector at CERN. In contrast to other environmental research infrastructures, EISCAT_3D is more similar to a detector in particle physics or radio astronomy when it comes to rates and volumes of data. Other available services, such as those developed by EUDAT (<http://eudat.eu>) are still in active development and as yet not suitable for a production system.

DIRAC provides both a command line interface (CLI) to interact with data search and job management, and a web-based graphical interface through which many but not all aspects of DIRAC are accessible.

In a nutshell, a summary of the portal information is given in the following table:

Tool name	EISCAT 3D Data Portal
Tool url	https://dirac.egi.eu:9443/DIRAC/
Tool wiki page	https://wiki.egi.eu/wiki/Competence_centre_EISCAT_3D
Description	The EISCAT 3D Data Portal is the main point of access to EISCAT 3D data and analysis. It allows authenticated users to access data archives and stage data for processing. https://www.eiscat.se/business/projects/egi-engage
Value proposition	This service will <ol style="list-style-type: none"> 1. Provide unified access to EISCAT archives of raw and analysed data and to computation 2. Allow EISCAT users to authenticate regardless of location

	<ol style="list-style-type: none"> 3. Provide metadata catalogue search as well as data mining 4. Allow users to cite used data 5. Allow EISCAT admins to enable ACLs according to EISCAT data access policies 6. Allows EISCAT and funding agencies to track the usage of EISCAT data
Customer of the tool	EISCAT associate and affiliate countries or institutes.
User of the service	Scientists in EISCAT associate and affiliate countries or institutes, but also the open data is for global use, within the of Geospace Environment research discipline. Main disciplines are atmospheric, ionospheric and magnetospheric physics.
User Documentation	https://www.eiscat.se/eiscloud/index.php/s/NNB5n7Ph44vTnf1#pdfviewer
Technical Documentation	See Appendix B
Product team	EISCAT, UAB, CNRS, CSC, Umea University
License	EISCAT 3D Data Portal source code, documentation, and release will be available under GPL license.
Source code	https://github.com/Eiscat3D/EiscatDIRAC

2 Service architecture

Within the ENVRI FP7 project, a pilot study was setup to identify existing services and new services that can tackle the EISCAT_3D big data challenge. Collaboration was formed among EISCAT_3D, EGI and the EUDAT infrastructures, and the first steps towards the EISCAT_3D big data strategy were taken.

At the end of the pilot, a small set of EISCAT level 1 (raw samples) and level 2 (spectral data) data, were transferred into the EGI and EUDAT federated clouds. A test portal was setup with crude metadata parameters and using OpenSearch, this portal can deliver data from the different storages within the clouds as well as from the EISCAT archive. The access rights of the portal were taken into account based on EISCAT's normal IPv4 address based rights as well as using certificates.

As the EGI Engage project started it was evident that the pilot would be difficult to be developed into a fully functional portal for the new radar EISCAT_3D with its much-enhanced technique with larger processing possibilities and data re-use.

The DIRAC prototype portal provides access to legacy EISCAT data and plotting of the data files. It is accessible at <https://dirac.egi.eu:9443/DIRAC/> and has been tested and debugged with help from the EISCAT user community.

- EGI core services integrated in the portal are:
 - dirac.egi.eu backed
 - VOMS authorization for community groups

- Perun user enrollment.
- The infrastructures currently used are:
 - EISCAT storage system
 - EGI Fedcloud
- The bug and requirements tracking system is the rt.egi.eu.

2.1 High-Level Service architecture

The EISCAT portal system comprises the DIRAC WebApp and CLI interfaces, user management, a metadata catalogue, and a data storage backend. Figure 1 shows an overall overview of the system. Some points to note:

- User management is based on membership in Virtual Organisations (VOs), managed by a Membership Service (VOMS) at <http://perun.cesnet.cz>, users registered with X.509 certificates.
- The proxy service. To enable access, the user certificate has to be uploaded to the proxy. The DIRAC CLI for proxy initialisation is the most versatile but there is also a WebApp.
- File access is handled through a storage element server running at the data provider (in this case at EISCAT Headquarters).
- Metadata search is the cornerstone of the portal and therefore a metadata catalogue is populated and updated regularly by software querying the data catalogue at EISCAT. The web app as well as the metadata DB run at Cyfronet⁵Through the job management system, data can be submitted to the plotting and reanalysis jobs that run in dedicated virtual machines (VMs) in the EGI Fedcloud.

⁵ <http://www.cyfronet.pl>

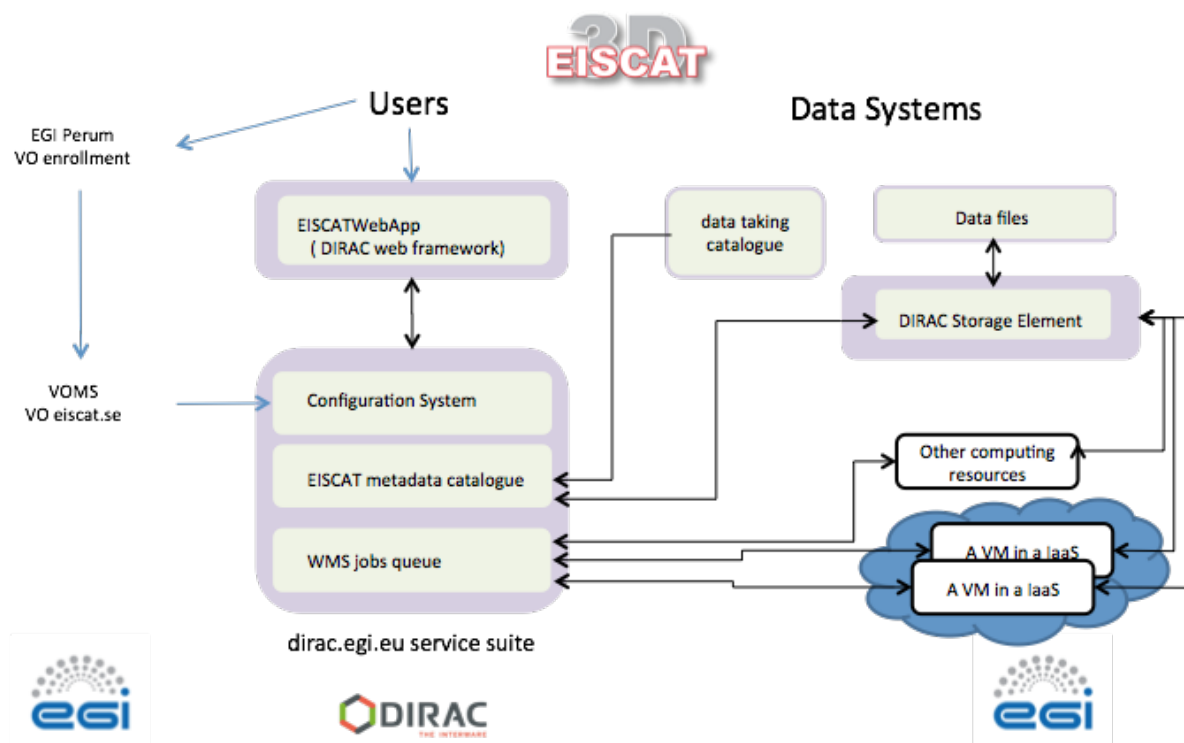

Figure 1. System overview.

2.2 Data used in the prototype portal

The files included in the prototype portal are EISCAT Level 2 data files, which means spectral domain (correlation) data vectors in a format different for each available radar pulse code. A description of EISCAT data levels is found in section 3.1. Currently EISCAT has separate storage and access systems for the archived data (Levels 2 and 3, with some Level 2 files also containing Level 1 data). The EISCAT Level 2 archive is a directory hierarchy indexed in a MySQL database, thus suitable as a model for the portal. Level 3 data, i.e. fitted physical parameters, are distributed through Madrigal (<https://www.eiscat.se/madrigal>), which has advanced APIs for search and retrieval (<http://www.openmadrigal.org>), but does not scale to other datasets than those that can in be represented as one- or two-dimensional tables with comparably few values.

The data files in the portal are compatible with the Matlab version 4 file format and compressed with **bzip2**. Libraries to read these formats exist for most commonly used programming languages; in addition to Matlab also Python, GNU R, etc. In the EISCAT_3D data model it is assumed that the archive file formats will be based on the HDF5 container standard and that the storage of data at the different data levels will be unified.

2.3 Data access

In Figure 2 the metadata cataloguing and data storage backend are highlighted. The metadata catalogue is created by querying the data catalogue at EISCAT, which lists data files at the granularity of hourly directories, with experiment information including

1. experiment name
2. antenna
3. experiment owner / accounting (EISCAT Associate country or institute)

A Python program runs monthly to perform this metadata catalogue update.

The DIRAC system accesses data from local storage at EISCAT. The data storage element is a dedicated server written in Python that listens on a TCP port and reads data from a directory that is a symbolic link to the actual EISCAT archive.

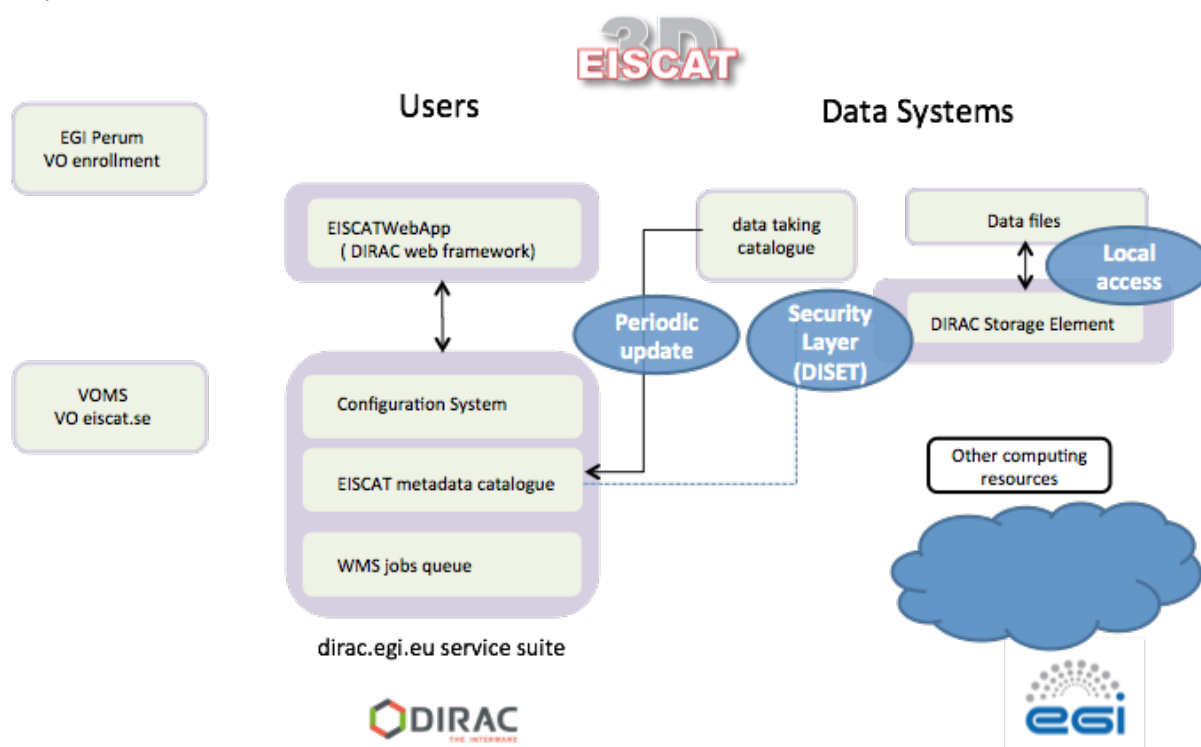

Figure 2. Data and metadata handling.

2.4 Community Policy based File access

The DIRAC portal for EISCAT data implements access control (Figure 3) by EGI VOMS group membership. One group has been created for each EISCAT associate, and also for Common Programme (CP) data and data management (Eiscat Owner group). The file access policy component grants access according to the following set of rules:

- All access, public or by group are secured by X 509 credentials

- Only *eiscat_owner* group can write in the archive space
- EISCAT users can write in their user space
- If a data file is older than a year, then access to all authenticated users is granted
- If a file is younger than a year, then:
 - If there is no account, then use country to check access
 - If the account/country is the same as the user credential group then allow access
 - If the account/country is CP then allow access

These and several more rules are implemented according to EISCAT statutes, the so-called Blue Book⁶.

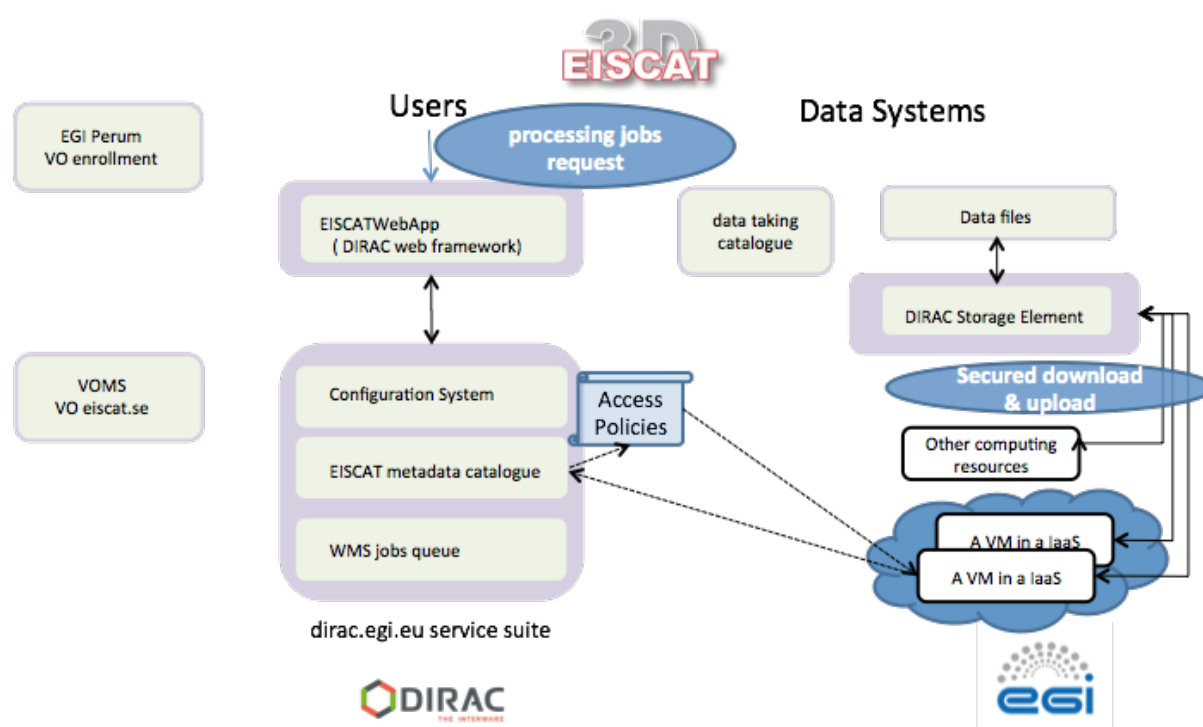

Figure 3. Access control management

2.5 User Request Workflow

The portal handles data access as described above and also submission of jobs to the EGI FedCloud services. Access to data and computing resources requires membership in a VOMS group of the eiscat.se VO. Users have to register through <http://perun.cesnet.cz>, and their requests will be approved or rejected by a VO administrator. See Appendix A for details. The principle of the workflow is (See also Figure 4):

1. User registers and is approved and enrolled in VOMS groups by the administrator.

⁶ Blue Book: <https://www.eiscat.se/scientist/document/bluebook/>

2. User searches for data
3. User selects data files
4. User selects a job to run on the selected data files (Job Manager applet)

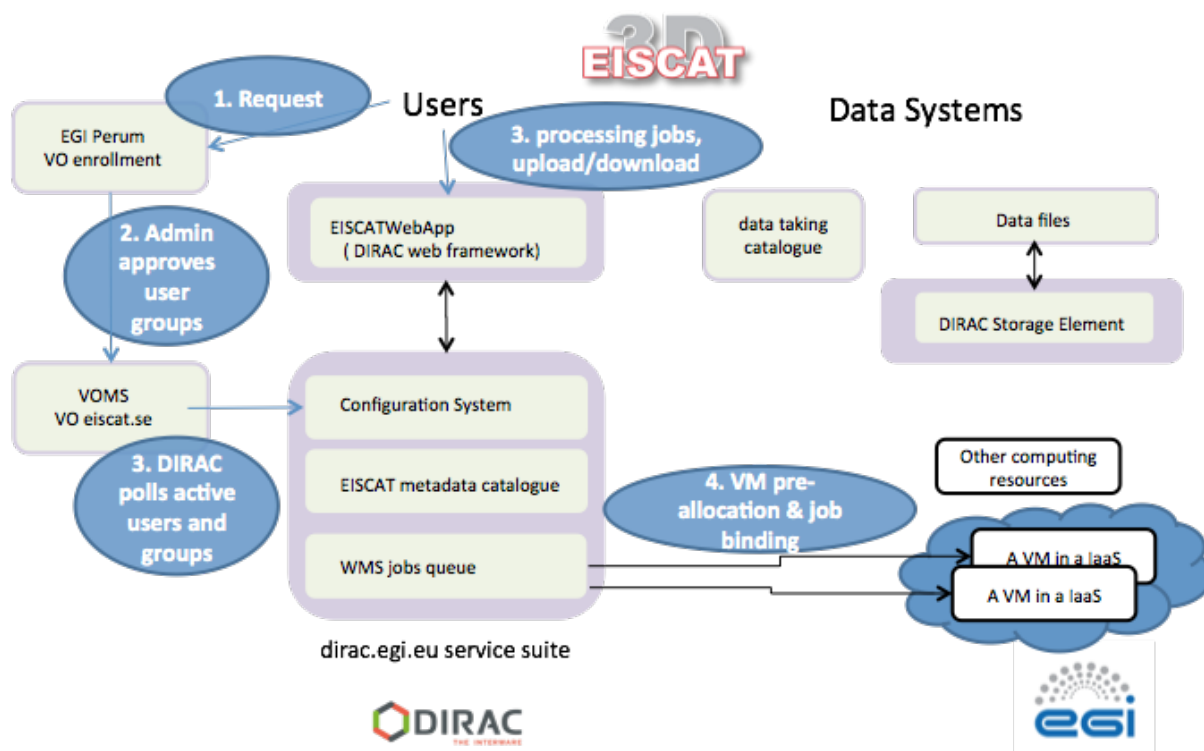

Figure 4. User request workflow.

The job is queued through the DIRAC Workload Management Service (WMS) and

1. A VM is allocated on EGI FedCloud resources
2. The VM accesses files from the Storage Element according to access policies
3. The job runs and analysis output is made available to the user (by GUI or DIRAC CLI)

This workflow has been tested by a number of EISCAT users and this has allowed us to provide feedback to the developers through the EGI RT system.

2.6 Portal interfaces

The existing portal setup contains GUI WebApps for data search and browsing, file download, and job submission. A detailed user instruction with examples has been written and distributed to the test users. This document is included as Appendix A. The following shows an example of each type of web application.

2.6.1 Metadata-based data discovery

Figure 5 shows how the user can select metadata criteria to search for.

- The user selects a top level directory and search criteria
- After selecting search criteria, a list of files will appear.

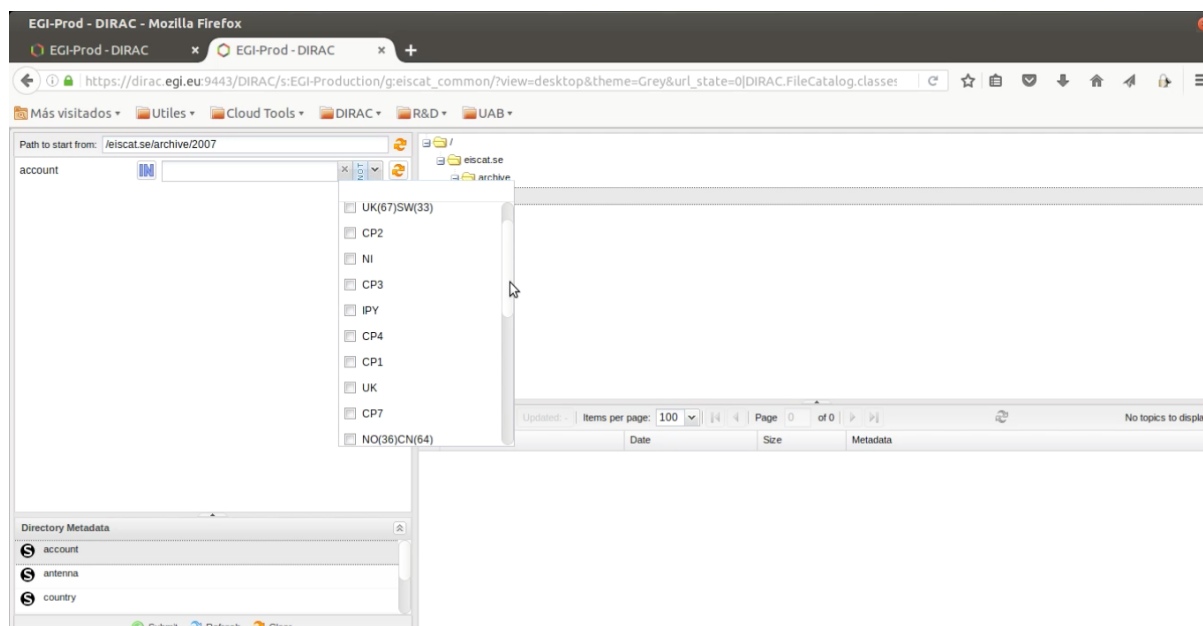

Figure 5: Metadata selection on the Portal GUI.

2.6.2 Data download

Figure 6 shows how users can download archives of individual data files.

- The user selects search criteria as above
- Files are selected by checking the boxes in the list on the lower right.
- The download icon will result in a query to the storage element and a zip archive of files will be created.

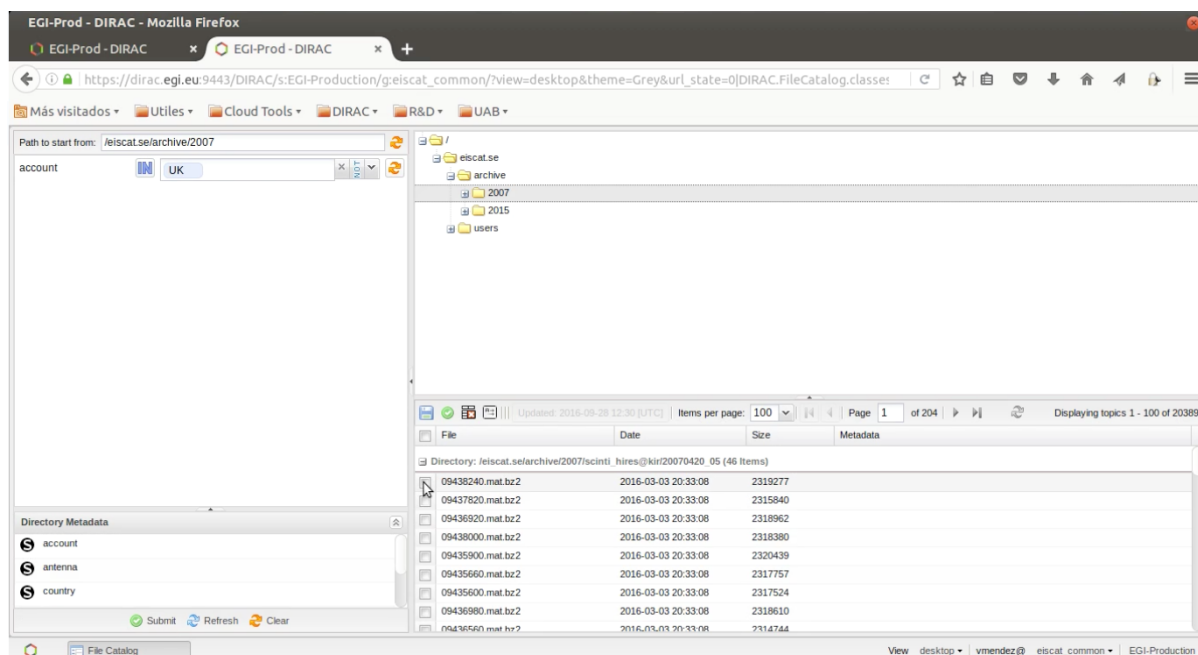

Figure 6. Data download in the Portal GUI.

2.6.3 Job Submission for Data Analysis

Figure 7 shows views on how selected data files are submitted to the plotting job.

- Upper figure: The user selects files and specifies the job to run in the Job Launchpad. In the Job Launch Pad, users can specify configuration files' location, and various parameters for data analysis. Once submitted, the status of job can be viewed in Job Monitor window.
- Lower figure: A result has been downloaded (PNG image showing a data vector). Once the submitted job has been successfully executed, the resulting plots can be directly downloaded from the portal.

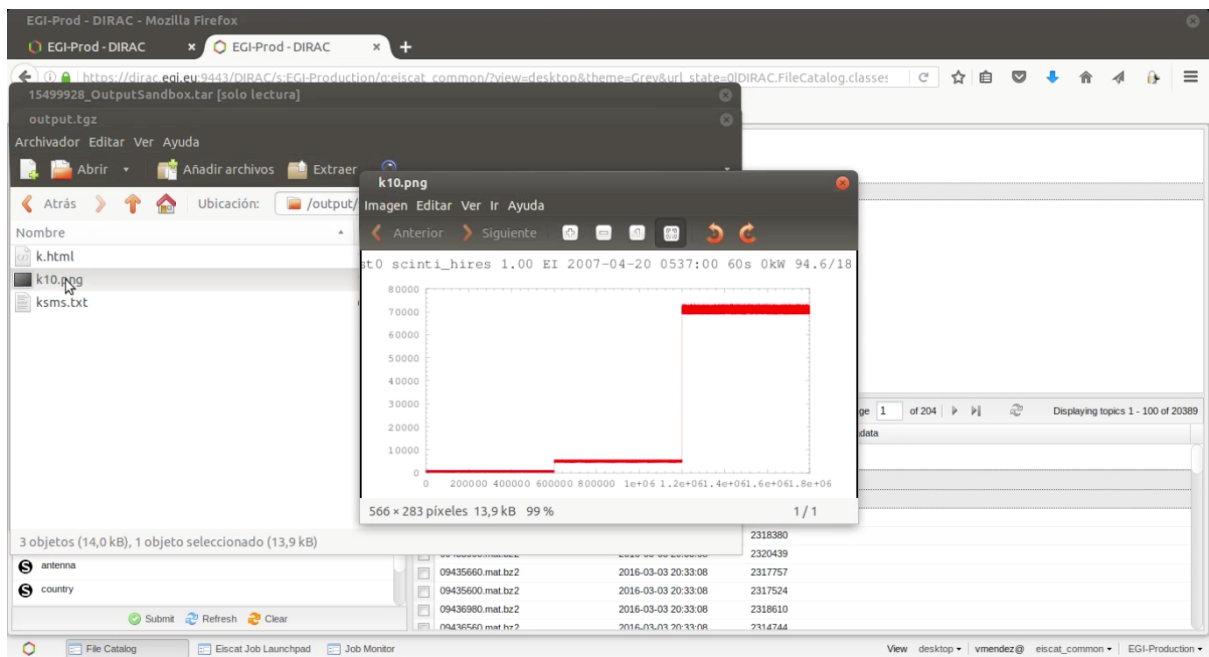
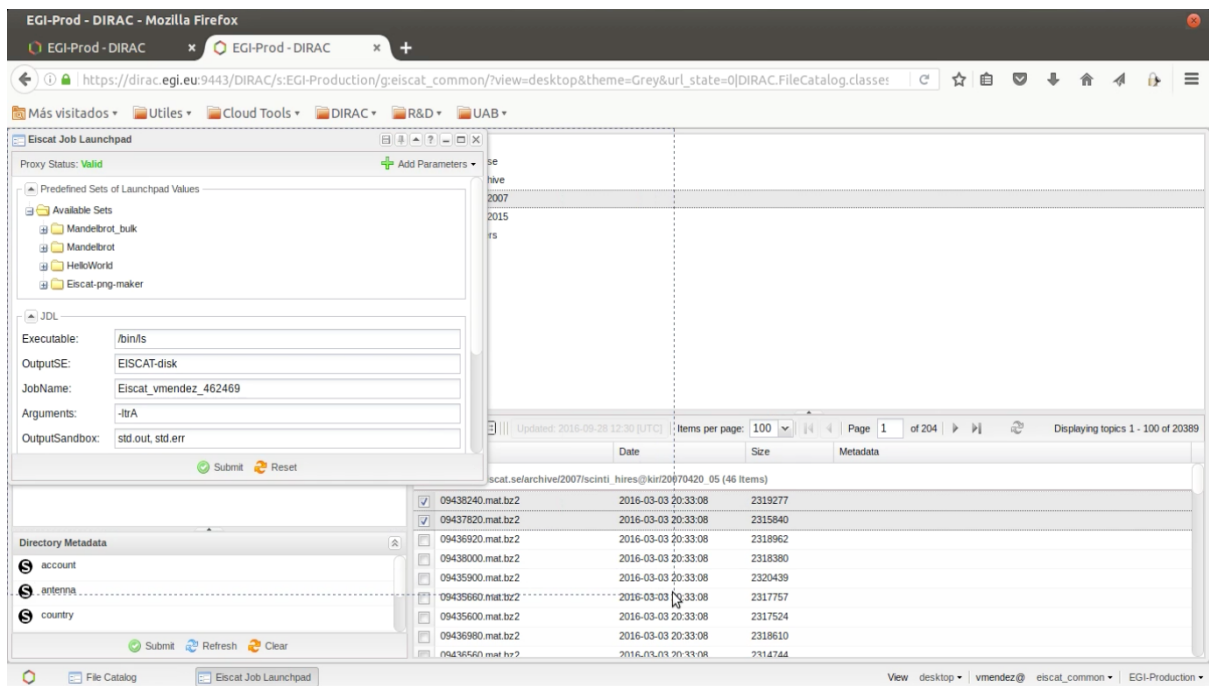

Figure 7. Plotting of selected datasets with plotting jobs in the Portal GUI.

3 EISCAT-3D Data Management

Development of a suitable data model to allow easy archival, access control, search and data mining of EISCAT_3D data is an integral part of the EGI-CC portal project although the present CC prototype portal is based entirely on the legacy EISCAT data model.

The EISCAT_3D project states that all data must be available online for at least 5 years after acquisition and older data easily retrievable from the archive sites. There will be two or more redundant archives. In order to analyse archived data, computing on demand at capacities up to several hundred TFLOPS will be necessary. The user portal system for EISCAT_3D will thus have to accommodate all the above requirements with respect to data and computing access, in addition to user authentication and data access authorization. This stresses the need for a well-designed data and metadata model. The end products resulting from the data model will be data and metadata catalogue schemas, which are likely to be implemented in SQL databases, as well as the actual archive file formats.

3.1 Data levels

The data handled in EISCAT and other incoherent scatter radars fall naturally into three categories, the data levels 1 to 3, according to the amount of processing and volumes of data.

Level 1: Filtered and time averaged voltage domain data from the radio receivers. Due to the data rates, data at this level are archived only for certain experiments. EISCAT_3D will archive a fraction of all Level 1 data to the extent allowed by archive space.

Level 2: Spectral (i.e. decoded to the autocorrelation domain) and time averaged data. Contains complex values representing weighted statistical samples of the autocorrelation function at certain lags and ranges. This is the data level archived in the legacy EISCAT system and is also intended to be the main archived data product from EISCAT_3D.

Level 3: Physical parameters, such as electron density and ion velocity, obtained by fitting a physical model to Level 1 or 2 data. In EISCAT_3D, also 3-dimensional volume renderings of those parameters.

Figure 8 shows schematically how data at these three levels are produced and handled in the legacy EISCAT system. Most importantly, data at Levels 2 and 3 are archived in separate systems. Those experiments that save Level 1 data include these raw samples in the same data files as the Level 2 data.

The Level 2 data are accessible through the schedule page system. A custom-developed Python program that listens for http(s) connections on a dedicated port handles file bundle downloads. The only access control is a check that the connecting IP address is in a member country.

The Level 3 data are distributed through Madrigal⁷, which is the de facto world standard for

⁷ EISCAT Madrigal database <https://www.eiscat.se/madrigal/>

distributing analysed parameters from incoherent scatter radars. Madrigal⁸ is based on web services with APIs for several languages and a web CGI interface. The file catalogue is a plain text file and storage is based on one directory per experiment. Thus this system does not scale well to data at lower levels than Level 3.

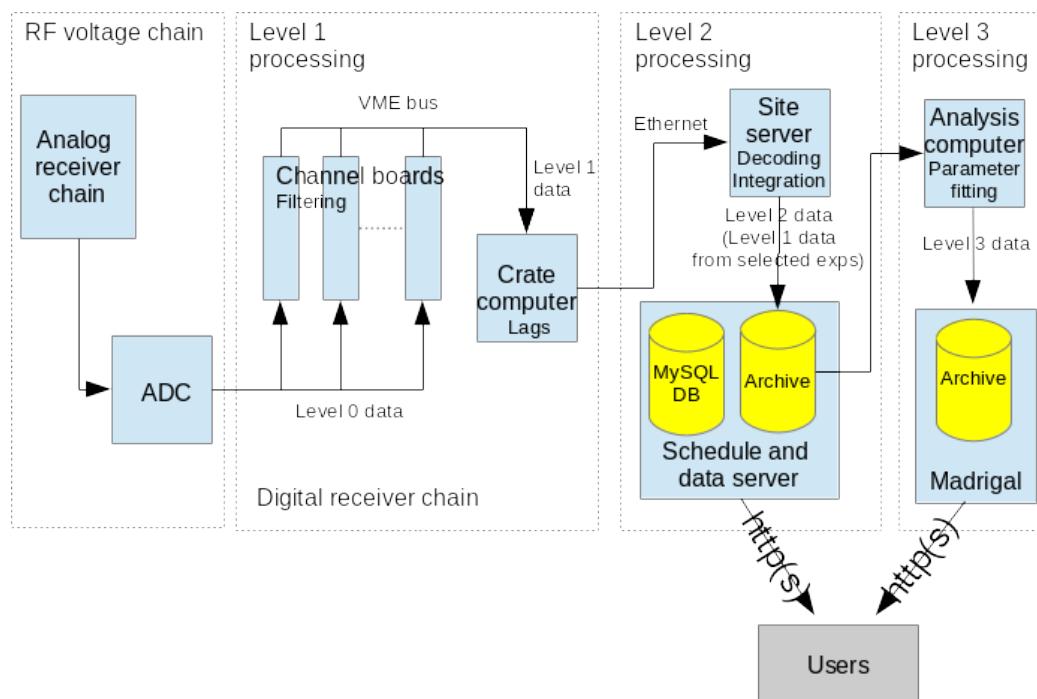

Figure 8: schematic overview of the receiver and data system of the legacy EISCAT radars. This figure shows where data at Levels 1, 2 and 3 are produced and how they are archived. Notable is that we use separate data distribution systems for Levels 2 and 3. User authentication functions in these systems are also rudimentary.

It should be clear from the above description and the figure that a system similar to the existing one is inadequate for EISCAT_3D. EISCAT_3D is also different from most environmental research infrastructures, rather resembling a radio astronomy system such as LoFAR and SKA or the LHC detectors at CERN. The major differences and complexities introduced by EISCAT_3D are

- EISCAT_3D will run multiple simultaneous experiments and beam directions. Data must therefore be separated accordingly. Authentication and data access will have to be handled per experiment.
- Scalability of archive. The data volumes will amount to several petabytes per year, whereas all data from the legacy EISCAT radars since 1981 fit on a RAID system of about 80 TB.
- Connection of data levels and citation of data used by EISCAT scientists. The separation of

⁸ About Madrigal <http://www.openmadrigal.org/>

data at different levels into different archive systems cannot be maintained. Persistent identifiers of data sets would also be needed in order to adequately enable proper data citation and tracking of data usage.

3.2 Data Model and metadata catalogues

A data model has to comprise both a description of the system and its users, as well as the data and metadata themselves. The EISCAT_3D data model should follow the ENVRIplus reference model⁹ and make use of standard data ontologies, i.e. sets of fixed definitions of every parameter.

This will be clearer by considering Figure 9 describing EISCAT_3D both from the point of view of the data flow at a site (part a) and at a system and user level (part b).

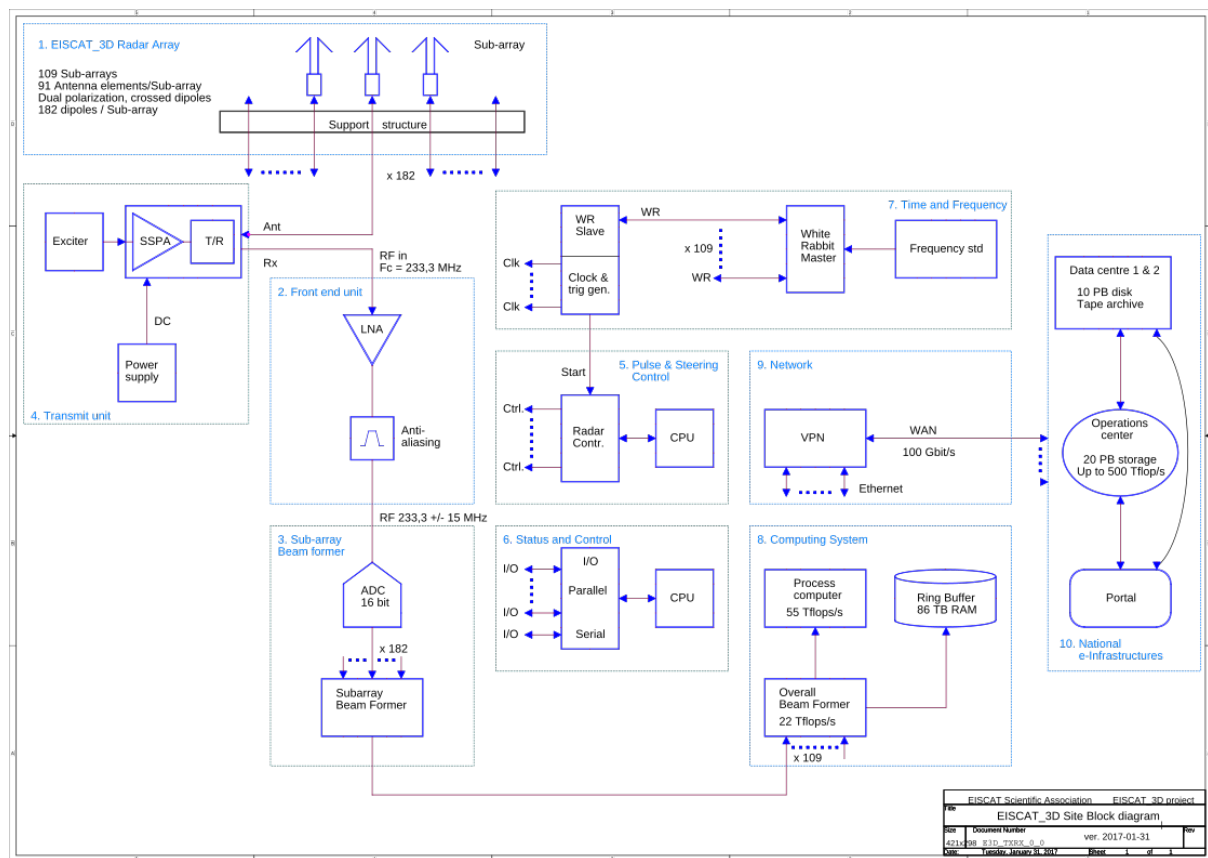

Figure 9, part a. Data flow at an EISCAT_3D site

⁹ ENVRIplus Reference Model: <https://confluence.egi.eu/display/EC/ENVRI+Reference+Model>

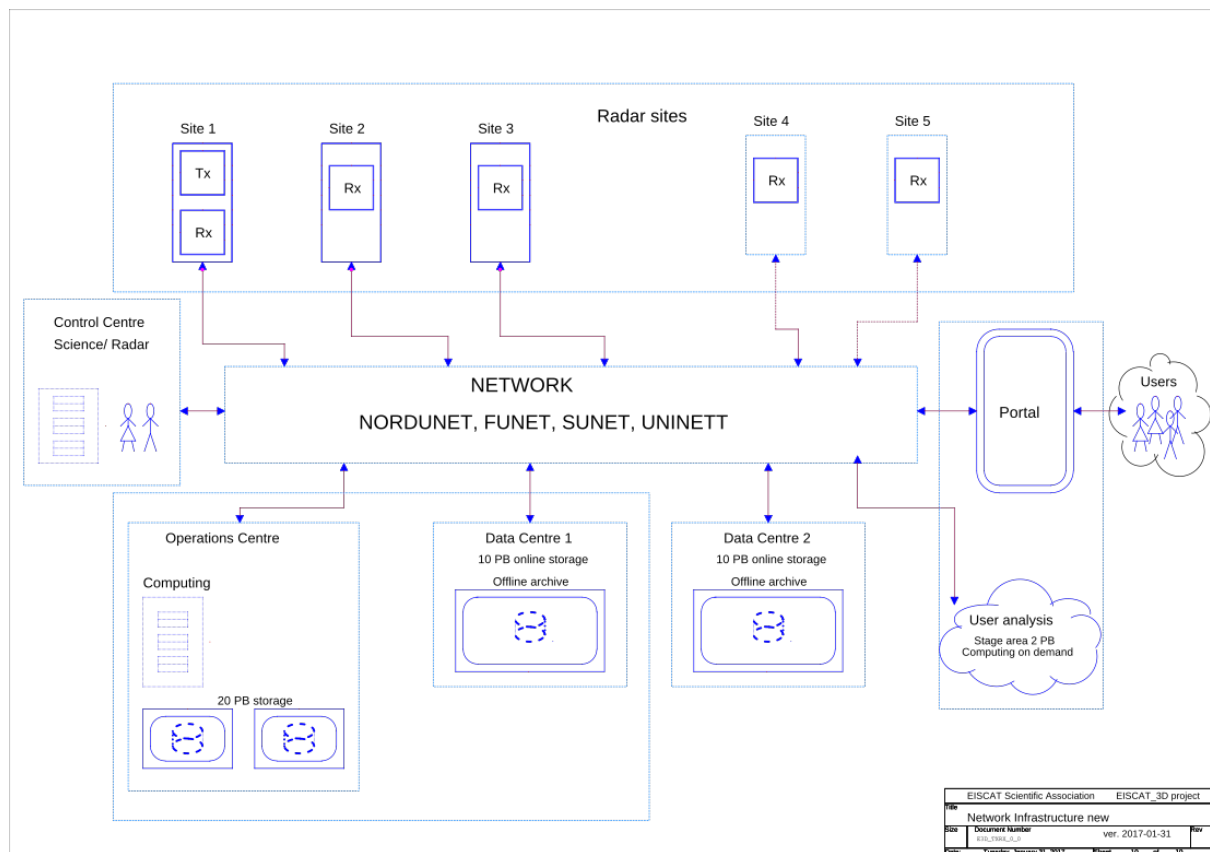

Figure 9, part b. EISCAT_3D from system and user perspective

From Figure 9 part a it is clear that

- a site with transmitters and receivers contains many configurable parts. These must be consistently described across the system and for every experiment setup.
- There will be data streams as well as production of files at Level 1, 2 and 3, all of which must be catalogued and curated with sufficient metadata.

Figure 9 part b shows the overall infrastructure from the data and user viewpoints.

- Searching and re-analysing several petabytes of data will be necessary in order to make full scientific use of the data. To the extent possible it will be necessary to find the data to analyse without opening every data file. The latter, however, will also be necessary in data-mining type studies.

3.2.1 Describing member organisations and users

The top level of the data model will be a description of

- member organisations
- persons in charge, at various levels
- possibly data users

There is a fairly standard and limited set of descriptions, such as affiliations and postal addresses, and personal IDs such as ORCID. A work document for designing this ontology can be found at

<https://drive.google.com/open?id=1a4KqwTsyv8B35s2yuuedMGE6ppEQR2beX-xz1SAQMts>

3.2.2 Describing and scheduling experiments

The basic concept of EISCAT operation and data is an experiment, which is

- one or several radar runs and their resulting data,
- scheduled for one EISCAT partner (associate, affiliate or peer-review access)
- or scheduled for use by all EISCAT partners (Common Programme experiments).

Special rules of access apply to the data associated with one specific experiment. In the following these data will be described and plans for EISCAT_3D data discussed based on experience from the legacy EISCAT radars.

The details about an experiment will include at least

- scheduling of start and end times of the experiment period
- specifying conditions to run in case of event-driven experiment runs
- prioritizing experiment applications
- setting up and changing beam directions
- selecting pulse codes

A work document specifying experiment descriptions can be found at

<https://drive.google.com/open?id=1TAJdFR8zuOukUC5eTLYjKdxSYEg2rMAZOpg77payDOE>

3.2.3 Describing the hardware

It is vital in EISCAT_3D to describe the sites and all subsystems i.e. antennas, subarray, arrays, and any other instruments, and what hardware that has been operating at what times. Without this information it is generally not possible to produce any sensible beam-formed and calibrated data at all.

Every hardware part will have an ID number at least at the level of the most important subsystem units. Such units will also include antennas and cables since antenna gain patterns and electric cable

lengths as function of temperature etc. affect the whole processing.

A work document of these specifications is available at

<https://drive.google.com/open?id=1a4KqwTsyv8B35s2yuuedMGE6ppEQR2beX-xz1SAQMts>

3.2.4. Describing the data at levels 1,2 and 3: the actual metadata of archived data

Sufficient metadata for search and data discovery, analysis, data provenance tracking and data citation must be attached to all data collections or files both in the files and at the file catalogue level. Requirements are specified in the work document at

https://drive.google.com/open?id=1pA7GAoV_dnUgMhluWMpy9b6aclgf9IKkZq5SBwdE0UY

3.2.5 Describing the metadata generated by the control systems

The metadata will come from several sources, the first one being the experiment configurations (which can be considered as setpoint values). The most important metadata are likely the actual acknowledged configurations and parameters reported by the control units of the system. As can be seen in the block diagrams there are many control subsystems including

- timing, overall site control and monitoring
- transmitter control
- receiver control

Required controller generated metadata is specified in the work document at

https://drive.google.com/open?id=1tEprIAWaj8e_3eNElvkAvoBS2nRZunHqy4_m7PStmyw

3.3 Data Formats

The actual data formats to be used in EISCAT_3D cannot be completely determined before the system exists. This section provides links to working documents where specifications of the requirements on the formats of both streaming and archived data at Levels 1, 2 and 3 and to engineering level (system monitoring) data are being collected. These documents are in a process of continual updates.

3.3.1 Data in the DIRAC portal

The current DIRAC portal provides Level 2 data from the legacy EISCAT radars and the available data constitute a subset of the data available through the EISCAT data and schedule server, <https://www.eiscat.se/schedule/>.

These Level 2 data files are stored in Matlab v4 *mat* compatible format and are compressed with *bzip2*. The storage format depends on the pulse code experiment used, available at <https://www.eiscat.se/wp-content/uploads/2017/04/Experiments.pdf>, shows what kind/s of data (e.g. ion line data in different resolution up- or downshifted plasma lines) that each experiment stores. The files also contain metadata in the so-called parameter block.

3.4 Data catalogue schemas

The data and metadata catalogues cannot logically be designed until the data model has stabilized and the details of the archival systems are known. The data model is under development and the archival system is a matter of selecting the site(s) that will archive the data. The latter will likely either be decided in a tendering process or provided by one or more facilities as an in kind contribution to EISCAT_3D.

However, at this stage we suggest that SQL databases, preferably in PostgreSQL, would be the natural implementation of the data and metadata catalogues, i.e. technically the same systems as in legacy EISCAT and the present DIRAC portal, but considerably more elaborate. A suggested schema based on earlier versions of the data model drafts exists, but can be considered obsolete:

https://docs.google.com/document/d/1wpN3pPYZt_F15CACMMs0XI9yeUZcXWRxAf7O57cAVqc/edit?ts=5909f247

4 Data Analysis

As we discussed in section 3, EISCAT_3D data will be stored at different levels, starting from the lowest levels of raw samples. Each level of higher degree is dependent of processing of data with certain assumptions. These will to different extents mean some degree of data destruction, so it's desirable to store as low level of data as practical. This is also important for the data re-use as new processes to data is constantly developed for both conventional data reductions as well as for new science fields. The versatile EISCAT_3D data has extraordinary possibilities for this.

The classical levels of EISCAT_3D data beam-formed raw(1) and spectral (2) data, and the physical parameters (3) of the incoherent scatter theory. EISCAT provides programs to go between these levels, and these are important for a user to be able to redo with other parameters than the default ones. In the Competence Center, a couple of these processes have been introduced mainly to see how well the portal can handle them. As it has been difficult to get access to larger processing resources within the project, only two sets have been considered: visualisation of the level 2 data and a proof of concept of a simple lagprofiling procedure.

4.1 Visualisation

EISCAT is providing a visualisation tool for the level 2 data. This is written in Matlab, but to avoid licensing issues, it has been adjusted for the open software of Octave. This is a useful tool especially when there are unusual scientific processes happening inside the radar beam, as the tool does not make much assumptions of the radar target. This is described in App A, section 5.

4.2 Lagprofiling

Going from level 1 to level 2 means in general to convert voltage data to power data to enable integration in space and time. This will reduce data size by approximately a factor of ten with small data destruction. The default integration, normally a few seconds, is in some circumstances way too long to enable good science.

4.3 Lagprofiler code and DIRAC

As a test case to implement analysis tools to DIRAC an existing code written for Matlab was chosen. This is the lagprofiler library for EISCAT data, to go from level 1 data to level 2. Original code was a Matlab script that called an external C code, that was responsible of the actual computing using external FFTW library¹⁰.

¹⁰ FFTW is a C subroutine library for computing the discrete Fourier transform (DFT) in one or more dimensions, see <http://www.fftw.org/>.

This code was used to strip from Matlab dependencies so that it could be compiled and run independently without Matlab.

Actions for the next steps will be as follows:

- Compiled code will be run as a DIRAC simple job. For more information, see <http://dirac.readthedocs.io/en/latest/UserGuide/Tutorials/JDLsAndJobManagementBasic/index.html> and Appendix 5 in this document.
- Plotting of results using Octave will be tested.
- Usage of external data repositories for input and output files will be tested.

5 Plan for Exploitation and Dissemination

Name of the result	EISCAT 3D Data Portal
DEFINITION	
Category of result	Software & service innovation
Description of the result	The EISCAT 3D Data Portal is the main point of access to EISCAT 3D data and analysis. It allows authenticated users to access data archives and stage data for processing. https://www.eiscat.se/business/projects/egi-engage
EXPLOITATION	
Target group(s)	Scientists in EISCAT associate and affiliate countries or institutes. Main disciplines are atmospheric, ionospheric and magnetospheric physics.
Needs	EISCAT_3D system will introduce significant challenges in the handling of experimental data, which will be generated at very high rates (Velocity), Volumes and Variety. These are typically referred to as big data problems (the 3V plus the Value) and require solutions beyond the capabilities of conventional database technologies and local computing facilities. The long timescale also demands stable but flexible methods for curation and provenance tracking and a plan for data migration.
How the target groups will use the result?	The portal will play a vital role in the EISCAT_3D system: it will provide services for researchers to discover, access and analyse (visualise, mine, etc.) data generated by the EISCAT_3D radar stations. Authenticated users will be able to add their own analysis components (as virtualized machines, containers etc.) which will

	then be available for all users.
Benefits	The portal will allow researchers to handle large-scale data generated by EISCAT 3D radar in an easier and more versatile way than for example data from the existing radars.
How will you protect the results?	EISCAT 3D Data Portal source code, documentation, and release will be protected by GPL license.
Actions for exploitation	The basic research of geospace environment carried out using the EISCAT_3D radar is the main science track, and the portal enables a powerful platform for the long-tail scientists. EISCAT has over the years fostered several SMEs and with the enhanced user base of the portal this is expected to continue.
URL to project result	https://dirac.egi.eu:9443/DIRAC/
Success criteria	The data portal is adopted by EISCAT community
DISSEMINATION	
Key messages	EISCAT_3D data portal provides a web-based user interface for searching, retrieval and re-processing (visualisation, analysis) of EISCAT_3D data
Channels	Scientific publications, EGI web site, EGI newsletter. The communities of EGI, EUDAT will be utilised for dissemination together with EISCAT users. Training events will be held in EGI/EUDAT as well as EISCAT conferences.
Actions for dissemination	Outreach to new users, for example in atmosphere and climate science, in addition to existing space physics users, is an important part of the EISCAT_3D project. Regular training events for scientists at all levels, from students to experienced radar users, will be necessary. Dedicated events will be organised at major conferences as well as specialised meetings such as the biannual EISCAT symposia and the annual European meetings on atmospheric studies by optical methods. Radar schools are also organised regularly.
Cost	4PMs
Evaluation	Uptake of the solution in the EISCAT community

6 Future Plans

6.1 Scientific and technical use cases

The future development of the portal is included in the EOSC-hub proposal responding the EINFRA-12 call. There we are aiming to go forward from the current pre-production portal to reach a TRL-8 level portal service through a *so-called* EISCAT_3D Agile Data Competence Centre.

This enterprise is going to be driven by a set of technical use cases, which require to integrate already existing EGI and EUDAT e-Infrastructure services and resources to cover present scientific needs and future scientific needs when EISCAT_3D is fully operational:

1. Integration of e-Infrastructure storage resources for the provision of data. The acquisition, processing and reprocessing of data will create multiple data levels to be accessed from replicated storages. The different data levels have different access policies. To manage such data provisioning, it is necessary to integrate several storage infrastructures (including e-Infrastructure storage resources e.g. EGI FedCloud) in a logical layer providing a unified access policy.
2. Integration of data analysis and visualisation services for three-dimensional volumes of both scalar and anisotropic parameters, such as measurements of the electron density or wind velocity vectors. Different scientific applications will need to be easily linked to the corresponding data in order to simplify the understanding of the available software and details of the data management, so that a scientist can focus on data analysis instead of the computing matters. For this use case we will follow a job computing model using EGI (and EUDAT) distributed computing and storage resources, together with the necessary e-Infrastructure services.
3. Using EGI FedCloud virtual resources for continuous operation with simultaneous or interleaved experiments for diverse purposes. This operational requirement requires a dynamic running environment on the computing resources, with agile deployment of the software stack as well as automatic release management of the involved software. For this purpose we will integrate EGI FedCloud virtual resource management services as well as containers composing infrastructures.
4. Integration of realtime data services for geospace alerting and optimal operation of the radar and collaborating instruments (including rocket launches, etc). This requires near real time processing of data from each radar site. In order to secure the unique raw data and to free up real time resources this does not necessarily require additional processing of low- level data but can use preliminary on-site analysis results at a low data rate. Handling real-time requests is still a challenge for e-Infrastructure technology and the investigation will look into this area.
5. Using e-Infrastructure technologies/services to handle large-scale re-analysis of data from unique events of interest, such as solar eruptions, auroras and more. This requires staging of

large data sets and potentially scheduling very long analysis jobs to run at times when real time processing is not running. The results of such re-analysis jobs should be stored, annotated with additional metadata and made available to other scientists.

6. Analysis of long term trends for climate change. This also requires staging of long time series of data although they will be re-analysed at a lower resolution. This being end-user use case, it is necessary to provide a set of software tools to the scientists, making the data, computing, software and deployment details transparent to the user.
7. Enabling science driven developments for new innovations in data analysis and radar technology and easy service deployment on e-Infrastructures. Early adopters of new algorithms and more specialised users analysing particular events must be enabled to easily deploy new tools, with necessary support from EISCAT and HPC staff. These tools will later be made available in an open source repository for general use by the science community.

The related technological needs are common to many research infrastructures, especially those used for environmental and space research where every measurement and data set is unique (in contrast to the controlled, repeatable laboratory experiments in fields such as particle physics). Considering this unique nature and comprehensiveness of the datasets from environmental research infrastructures including EISCAT_3D one expects much re-use of them for different fields of research with varying processes of analysis. This means that the tools developed here will also form a base for further integration of EISCAT services with e-Infrastructures such as EGI FedCloud, EUDAT B2 Service Suite and INDIGO service solutions, and for promoting these to the EISCAT scientific community.

The proposed EISCAT_3D Agile Data Competence Center (E3D-AD) is the natural evolution of the current EGI-Engage Competence Centre for EISCAT_3D.

In the last phase of CC-EISCAT3D, a subset of the final users has been engaged in testing data and application cases in order to reach a production level in a controlled environment. Furthermore, source code and documentation will be available under GPL license.

The promising results of our prototype have demonstrated the feasibility of the DIRAC Web App framework to agile development of the EISCAT_3D portal components of the frontend and backend, taking advantage of existing web applications and widgets, as well as enabling a straightforward suit with the DIRAC EGI core service as a backend. The use of DIRAC ensures a good scalability of job processing and data management. This is a critical point in the adoption of DIRAC as an integral solution for the extreme scale computing of EISCAT_3D horizon, and at the same time our CC-EISCAT3D prototype has demonstrated sufficient flexibility to adapt the solution to our specifics.

So far, we have a prototype portal service suite, which has been proven good enough for our initial requirements. We propose the new EISCAT_3D Agile Data Competence Center, to deploy and integrate necessary tools, services and infrastructures for our challenge of data management and processing for the EISCAT_3D ramp-up by 2019, including more and more users and scientific use cases. Our timeline is demanding so we would like to use the same architecture of DIRAC as an

integration component with a single access point, to take advantage of several common services and resources from the EGI, INDIGO and EUDAT consortia. The resulting system will be a value added service in the required data operations of the production stage, reaching TRL9 to drive EISCAT_3D operations during years beyond the scope of the present proposal. On one hand, the EUDAT B2 Service Suite will help to unify the data management system across different storages, including storage access management which is a critical factor in EISCAT_3D. On the other hand, a number of EGI and INDIGO services will help deploying complex running software stack in an easy manner, including release management, as well as secondary services which are necessary in a production environment in a large community.

6.2 Services and resources

The present proposal of EISCAT_3D Agile Data Competence Center is aiming at integrating EISCAT_3D data services and user analysis with EGI, INDIGO and EUDAT common services and resources, using the following:

EISCAT Agile Data Portal: We already have a pre-production portal with all the necessary services and components, as well as software tools for the integration of other services in this single access point. In our present proposal we need to update the portal in order to integrate the new scientific use cases:

- Configure user templates with scientific use cases and the required software stack to the portal automation of the corresponding deployment in the virtual machine / containers (Assessment with STUC#1 to STUC#7).
- To integrate the new scientific use cases metadata in the portal catalogue to enable the scientist to file discovery (Assessment with STUC#1 to STUC#7).
- Deployment of portal operations and incident management (GGUS).

Data Repository Services: Deployment of an EISCAT_3D data repository with simulated radar data to have a testbed for the future complete file processing chain (Assessment with STUC#2). This will be critical to ensure a scalable ramp-up by the end of the present proposal.

EISCAT_3D will enable several new scientific use cases due to its three-dimensional imaging of many parameters. Sufficient data need to be integrated with the portal in a consistent manner to provide a single data access point on top of the data services.

Authentication and authorization: Simplify user access to the data portal, as well as resource and data authorization system based. For this purpose, this we need to get unified federated identity from B2ACCESS and the access token to be used with B2SHARE. We propose to integrate this architecture with the current complex EISCAT access policy, which includes EISCAT group management to enforce the data embargo rules set by the EISCAT data policy (Assessment with STUC#1 and STUC#2). At the same time this will need an adaptation of the current portal authentication based on certificates to the federated id, and the EISCAT group matching

(Assessment with STUC#1). It also requires to implement federated id and token access persistency at the portal.

6.2.1 Cloud resources

Analysis of EISCAT_3D data may run on EGI cloud resources as well as on EISCAT_3D radar sites. In the latter case, different software and data tools for real time operation (Assessment with STUC#4) and user (re)analysis (Assessment with STUC#5) will be implemented using virtual machines or lightweight containers that will be switched according to experiment schedules. Furthermore, due to the scheduling of EISCAT_3D, where several experiments may be interleaved or use the same raw data, parallel analysis pipelines will be necessary to obtain a data aware scheduling (Assessment with STUC#3). A set of standard analysis routines for real-time as well as event analysis will be provided by collaborators in the EISCAT_3D project.

6.2.2 User analysis resources

Advanced EISCAT users, some of which will be the early adopters of the system under development, are also expected to develop their own analysis software for specific tasks, including STUC#6 and STUC#7, but also other scientific use cases beyond the scope of the present proposal, which will follow the same add value services and resources. Examples of such future user analysis use cases are sub-beam resolution interferometry, asymmetry of spectra, space debris counting, imaging of near-Earth objects, and analysis of middle atmospheric phenomena. Such software must be adapted and deployed on analysis VMs / containers and these advanced developer-users may need much assistance from the competence centre.

7. References

EGI RT tickets of issues solved in the current version of the portal

<https://rt.egi.eu/rt/Ticket/Display.html?id=11134>

<https://rt.egi.eu/rt/Ticket/Display.html?id=11197>

<https://rt.egi.eu/rt/Ticket/Display.html?id=11376>

<https://rt.egi.eu/rt/Ticket/Display.html?id=11377>

<https://rt.egi.eu/rt/Ticket/Display.html?id=11409>

<https://rt.egi.eu/rt/Ticket/Display.html?id=10878>

<https://rt.egi.eu/rt/Ticket/Display.html?id=11077>

<https://rt.egi.eu/rt/Ticket/Display.html?id=11198>

<https://rt.egi.eu/rt/Ticket/Display.html?id=11850>

<https://rt.egi.eu/rt/Ticket/Display.html?id=12263>

<https://rt.egi.eu/rt/Ticket/Display.html?id=12269>

<https://rt.egi.eu/rt/Ticket/Display.html?id=12486>

Appendix A: EISCAT Portal User Guide

In order to help EISCAT users understand how to access to the portal, we have provided a user guide as follows.

A.1 Introduction

A.1.1 DIRAC

EGI, first European Grid Initiative, later European Grid Infrastructure, and now simply EGI, <http://www.egi.eu> is an organisation sited in Amsterdam that federates access to computing and storage facilities in Europe. The H2020 EINFRA-1-2014 project EGI-Engage supports a number of competence centres (CC), one of which is the CC for EISCAT 3D.

The EISCAT 3D CC aims at developing the EISCAT_3D user portal, which is to be the primary interface through which users will browse, download and analyse EISCAT 3D data. We are investigating several options and have chosen to work closely with the developers of the Distributed Infrastructure with Remote Agent Control (DIRAC) project, <http://diracgrid.org>, which was originally developed for distributing data from the LHCb project at CERN. DIRAC is an interware, mostly written in Python, that provides command-line, web, and API interfaces to grid computing and storage resources. A major task in the EISCAT 3D CC has been to implement a prototype DIRAC portal for legacy EISCAT data from the years 2007 (IPY) and 2014 through 2016.

A.1.2 Layout of the EISCAT DIRAC service

The present prototype EISCAT DIRAC portal comprises the required functions for authenticated users to download standard correlated data, archived in Matlab-compatible format, and to submit selected data to the EISCAT real time graph (RTG) plotting software through the job management system. Specifically, the prototype DIRAC service consists of:

Virtual organisation membership service (VOMS) User access to the EISCAT DIRAC portal is managed through membership in groups in the EGI Virtual Organisation (VO) egi.se.

The VOMS used by EGI is called Perun and runs at Cesnet, accessible to VOMS managers through a web GUI at <https://perun.cesnet.cz>.

Storage element This is a Python program that runs on a dedicated port on a Linux computer at EISCAT Headquarters. It reads and serves data files from a top level directory, where the 2007 and 2013–2017 data directories are linked from the actual storage.

File catalogue This database runs on EGI resources at Cyfronet (<http://www.cyfronet.krakow.pl>) and

allows users to list and search the data with a command-line client and the file catalogue application in the web portal.

It is updated by a Python script that runs monthly (from cron) on the DIRAC server at EISCAT Headquarters.

Web interface A web interface is the main point of access for users. It also runs at Cyfronet and is accessible at <https://dirac.egi.eu:9443/DIRAC/>.

This web interface presents the user with a desktop (Fig. A.1) that looks much like the desktop of any modern computer environment. It has applications for file catalogue search, job submission, and more.



Figure A.1: The DIRAC web GUI

A.2 Getting access to the DIRAC portal

Access to data in DIRAC requires authentication with X.509 certificates. This has proven to be a difficult hurdle for most users to overcome. For typical EISCAT users the procedure described below should work.

1. Log in to your certificate authority. At least for EISCAT users in the Nordic region, this is usually Digicert. Browse to <https://www.digicert.com/sso/> using a compliant browser.

Firefox, MS Internet Explorer and Safari should all work, but to my best experience Google Chrome and MS Edge are not compatible. On the first page shown you will have to type in the name of your identity provider, i.e. your university or institute. Fig. A.2 shows what this looks like for the author, whose identity provider is the Swedish Institute of Space Physics. This will redirect you to a login page where you should be able to log in with the user credentials of your organisation. In many cases this will be the same name and password that you use for your university email and internal web pages.

2. Request a Grid Premium certificate by selecting this in the Product menu and clicking Request certificate, as in Fig. A.3. Depending on your browser, the certificate may be installed automatically as part of this step. If not, follow the next step below.

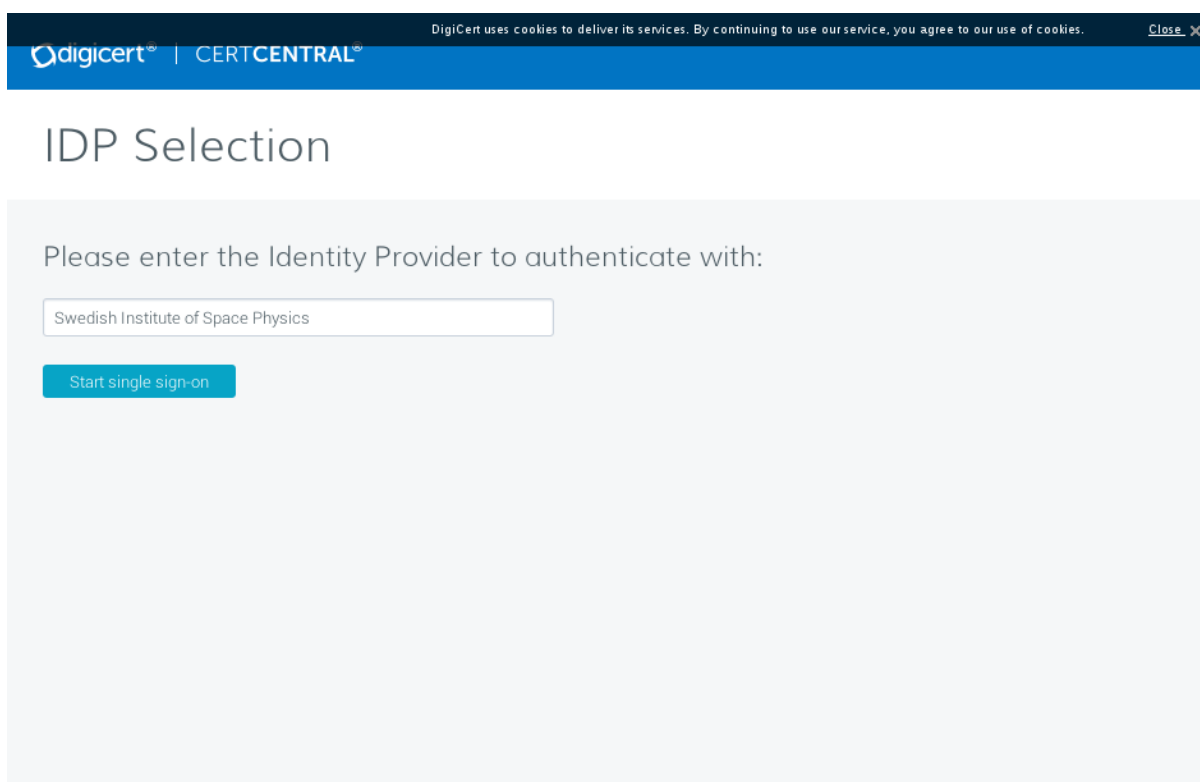

Digicert uses cookies to deliver its services. By continuing to use our service, you agree to our use of cookies. [Close](#)

Digicert | CERTCENTRAL

IDP Selection

Please enter the Identity Provider to authenticate with:

[Start single sign-on](#)

Figure A.2: Providing the Identity Provider information to Digicert. Type the name of your provider (such as University of X). This figure shows the author typing in his identity provider, which is the Swedish Institute of Space Physics for Eiscat HQ staff.

3. If the Request procedure did not install the certificate automatically in your browser, it can be downloaded by looking up the new certificate in the list My certificates and clicking the download button. This will give you a zip archive with your personal certificate together with a few other authority files. The certificate file (called something like yourname.crt) can then

be imported. Fig. A.4 shows the details of the author’s certificate after a successful import into Firefox.

4. Register to the eiscat.se VO through the Perun service at <https://perun.metacentrum.cz/cert/registrat/?vo=eiscat.se>. You will have to enter required information and then wait for approval. Fig. shows a completed successful registration.
5. Ask a VO manager (e.g. the author) to add your VO user to the access groups that you are entitled to (usually your EISCAT associate country and common programme data). Fig. A.7 shows how the author edits his own access groups and a similar procedure must be performed for your account. Upload your certificate to the DIRAC proxy, which is the gateway that allows you to access the DIRAC grid services. This is easiest using the DIRAC command line tools. They are Python and UNIX (bash) shell scripts. If you cannot install them, the GUI also provides a proxy upload applet.
 - Install the DIRAC client tools. Refer to <http://diracgrid.org> for this procedure.
 - Export your X.509 certificate in P12 format. The export function of common web browsers is useful. This will ask you to set a password for encryption.

The screenshot shows the Digicert CERTCENTRAL interface for requesting a certificate. The form includes the following fields:

- Product:** Grid Premium
- Validity Period:** 1 Year
- CSR:** (optional)
- Common Name:** Carl-Fredrik Enell fredrik@irf.se
- Email:** carl-fredrik.enell@irf.se
- Organization:** Institutet foer rymdfysik

Below the form is a 'Request Certificate' button. Underneath, the 'My Certificates' section displays a table with the following data:

Order #	Date	Common Name	Status	Product	Expires	Download	Revoke
961495	26 May 2016 12:58	Carl-Fredrik Enell fredrik@irf.se	Issued	Grid Premium	25 Jun 2017 08:00	Download	Revoke
964059	30 May 2016 15:51	Carl-Fredrik Enell	Issued	Premium	30 May 2017 08:00	Download	Revoke

Figure A.3: Requesting a Grid Premium certificate from Digicert.

- Option 1: Use the web GUI (see Fig. A.6) to upload your certificate to the proxy.
 - Select the Proxy upload applet in the web GUI
 - Browse to your p12 format certificate
 - Type in the password of the p12 certificate
 - Click Upload
- Option 2: Use the DIRAC CLI to install the certificate for the DIRAC services and upload to the proxy:

```
dirac-cert-convert.sh <YOUR_CERTIFICATE>.p12
```

- Upload the certificate and initialise the DIRAC proxy:

```
dirac-proxy-init -M -U -g eiscat_<GROUP>
```

for example:

```
dirac-proxy-init -M -U -g eiscat_FI
```

You will be asked for the password of your certificate (the one you set in the export step above).

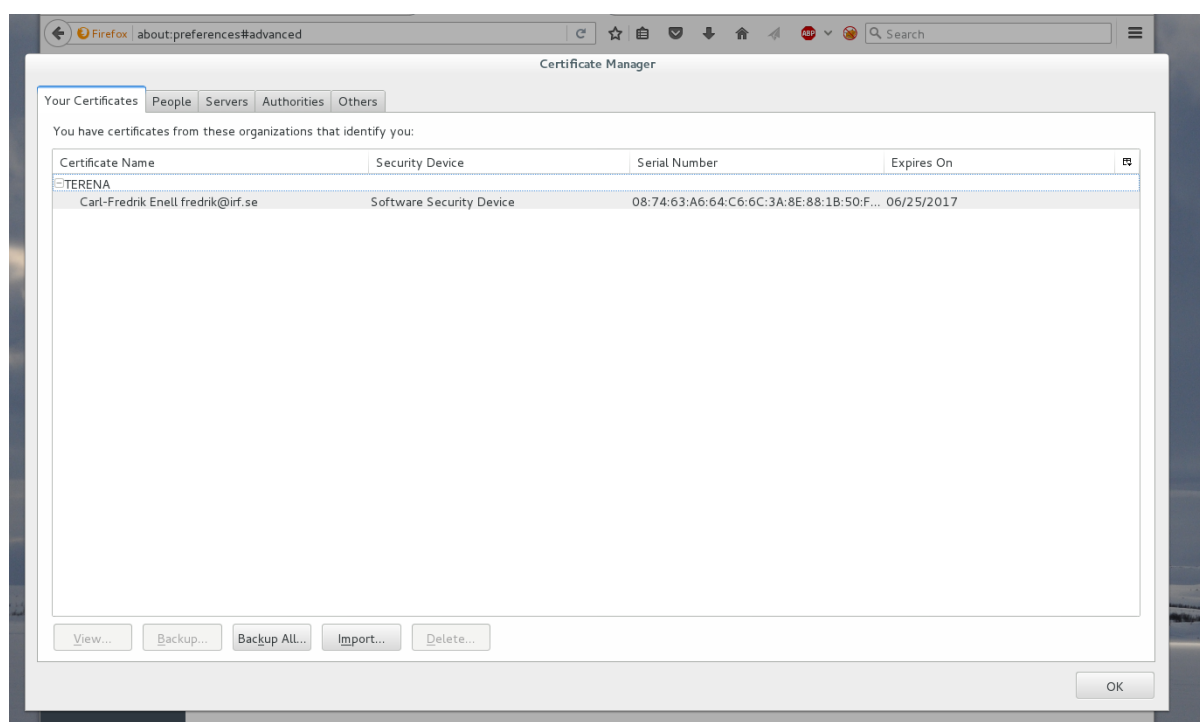

Figure A.4: The certificate manager in Firefox (Edit → Preferences → Advanced → Certificates)

After successfully importing a certificate from Digicert You can then check whether the upload succeeded like this:

dirac-proxy-get-uploaded-info

and you should then see something like

Checking for DNS /DC=.../DC=.../DC=.../C=.../O=.../CN=...

UserName	UserDN	UserGroup	ExpirationTime	PersistentFlag

...				
<div style="display: flex; align-items: center;"> < 📄 Registration to EGI eiscat.se VO </div>				
<div style="display: flex; justify-content: space-between;"> Submitted 2016-01-21 14:16:11 </div> <div style="display: flex; justify-content: space-between;"> Approved 2016-01-21 18:04:48 </div>				
Form content				
certDN *	<input type="text" value="/DC=org/DC=terena/DC=tcs/C=SE/O=Institutet for Rymdfysik/CN=Carl-Fredrik Enell fredrik@irf.se"/>			<i>value verified by Identity provider</i>
certDNhidden *	<input type="text" value="/DC=org/DC=terena/DC=tcs/C=SE/O=Institutet for Rymdfysik/CN=Carl-Fredrik Enell fredrik@irf.se:/C=NL/O=TERENA /CN=TERENA eScience Personal CA"/>			<i>value verified by Identity provider</i>
Given name *	<input type="text" value="Carl-Fredrik"/>			
Surname *	<input type="text" value="Enell"/>			
E-mail *	<input type="text" value="carl-fredrik.enell@irf.se"/>			<i>value verified by Identity provider</i>
E-mail *	<input type="text" value="carl-fredrik.enell@eiscat.se"/>			
Why do you want to become a member? *	<input type="text" value="EISCAT_3D portal development project"/>			
Login *	<input type="text" value="cfenell"/>			

Support: fedcloud-ff@mailman.egi.eu, diego.scardaci@egi.eu
Powered by Perun © 2017 CESNET & CERIT-SC

CESNET

[CONTACT](#)

[PERMANENT SERVICE](#)

Figure A.5: Registration to the EGI VO eiscat.se through Perun.

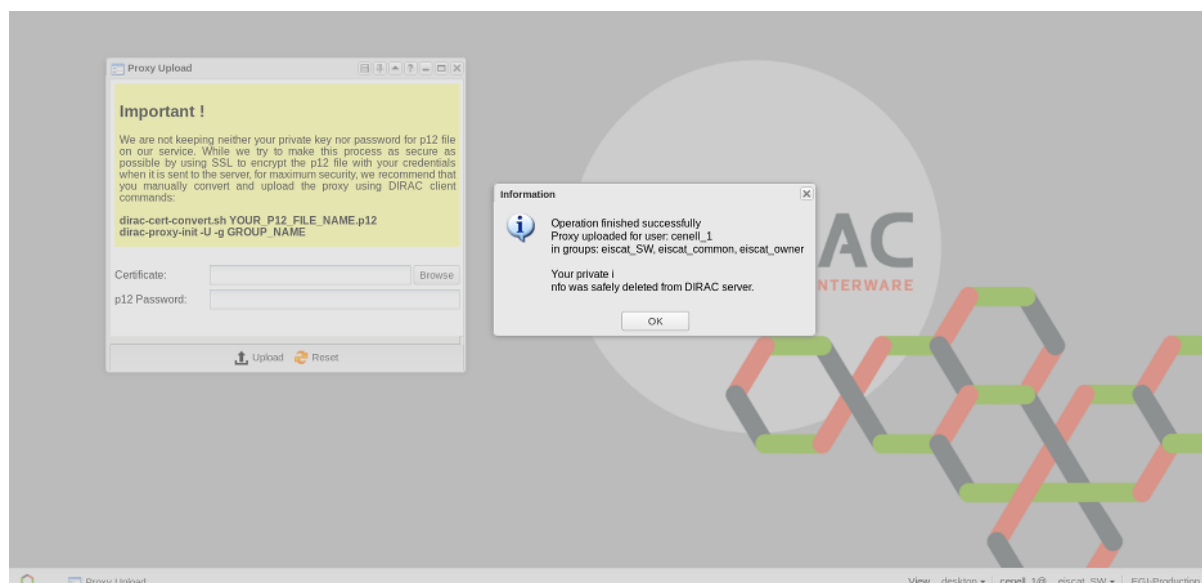

Figure A.6: Proxy upload through the web GUI

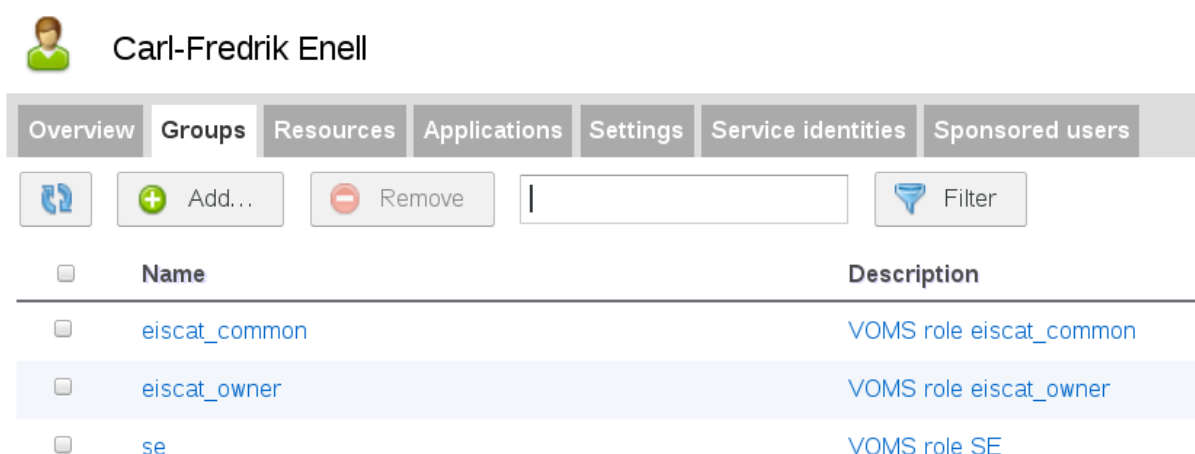

Figure A.7: The Groups tab of the Perun VOMS GUI, showing access groups of the author.

This registration will be handled by one of the VO managers so as a normal user you will not see this. It is important that you are a member of the appropriate VOMS group(s), however.

A.3 Searching EISCAT data

Once you have an installed certificate, VOMS group access, and an initialised DIRAC proxy, you can

start using the web GUI.

1. Go to the prototype portal at <http://dirac.egi.eu:8090/DIRAC/>
2. Select Secure connection at the bottom right. The browser may ask you to select certificate once or twice.
3. Select your VOMS group at the bottom right, e.g. eiscat FI
4. Go to the Windows style menu at the bottom left and browse to the file catalogue GUI.

A.3.1 Basic search

- The file catalogue GUI will look much like any file browser. The search will, however, start from a top level directory that you select by right-clicking on a directory in the listing (top right pane) and then clicking Set as starting path (See Fig. A.8). EISCAT data are in the directory hierarchy `eiscat.se/archive/<year>/`.
- After setting the starting path, additional search criteria can be added using the GUI in the top left pane. See Fig. A.9.
- Click Submit (below the bottom left pane).

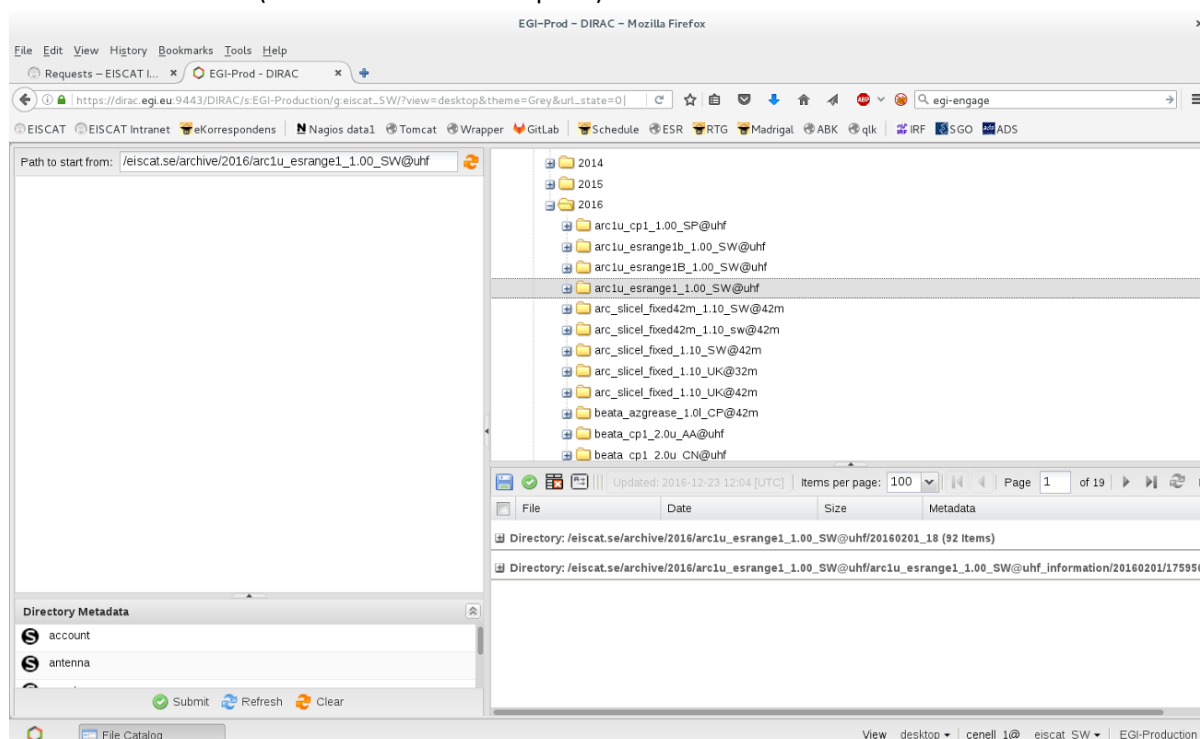

Figure A.8: Selecting a top level directory in the file catalogue GUI

The search will list any found files in the bottom right pane. After finding the desired files, you can select files for download or processing in the bottom right pane.

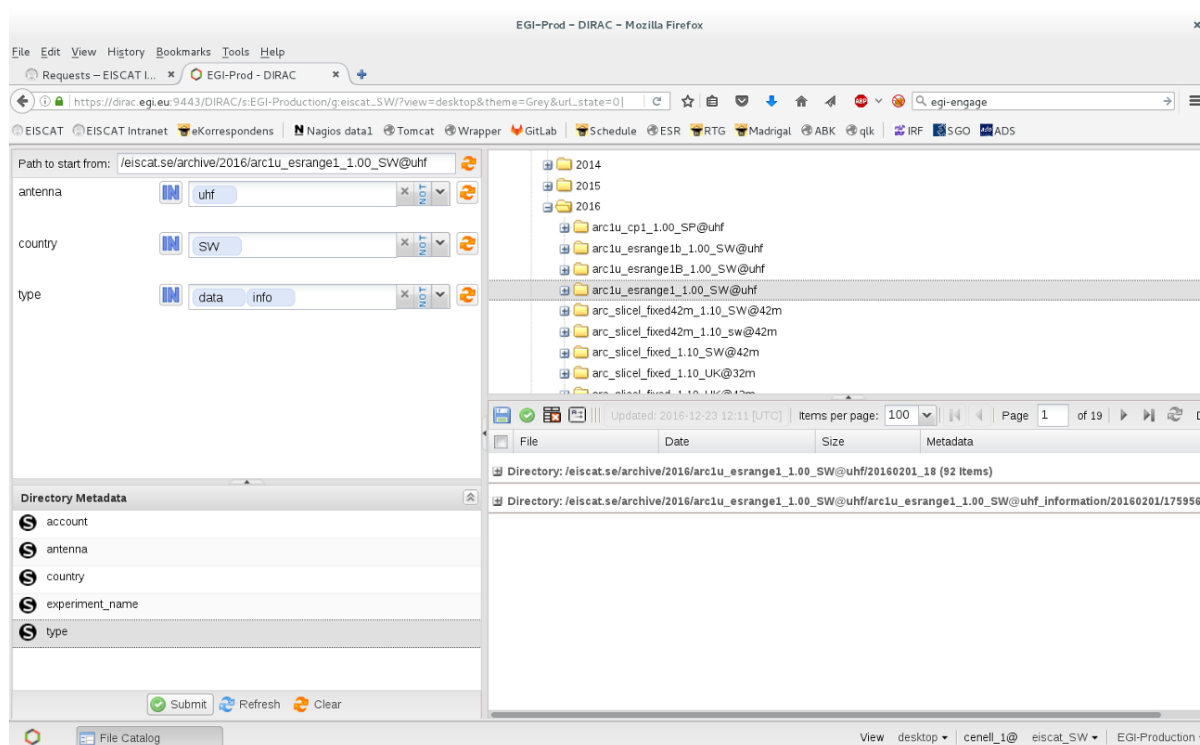

Figure A.9: Adding metadata search criteria. In this particular case, the top level directory contains only SW UHF data, so the filters shown as an example on the top left will have no effect. After selecting the search criteria, click the Submit button

A.4 Downloading EISCAT data

Files selected in the bottom right pane can be downloaded as a ZIP archive by clicking on the diskette icon, as shown in Fig. A.10.

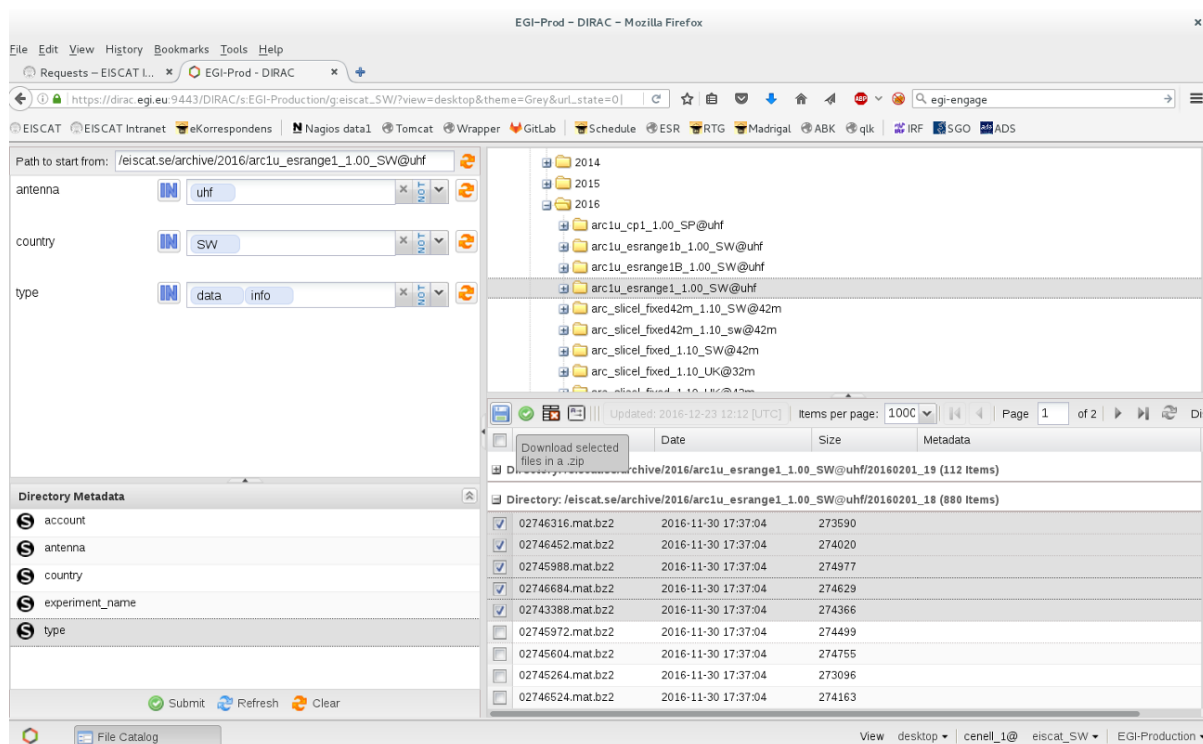

Figure A.10: Selecting files to download.

A.5 RTG plotting of EISCAT data files

The GUI can also submit processing jobs to the EGI grid. This procedure will usually

1. start a virtual machine on grid resources
2. run the specified software with the selected files as input. At this stage the standard EISCAT Real Time Graph (RTG) has been implemented and will plot the content of the selected data files (by running the RTG script on the open source Matlab-compatible software Octave).

The procedure is as follows

1. Select files as for download
2. Click the green job launchpad icon above the file list
3. The job launchpad GUI opens. Right-click on the EISCAT png maker directory icon and select Apply to the selected parameters. See Fig. A.11. The field Executable should now show the path to `webtg4dirac`.
4. Check the other parameters as well and click Submit at the bottom of the job Launchpad window.
5. Go to the main menu and browse to the job monitor (Fig. A.12). Make sure that your user

name is preselected and click Submit to see the status of the job.

- Once the job is finished, the output will be in the Sandbox. Right-click on the job line to see the menu as in Fig. A.13.

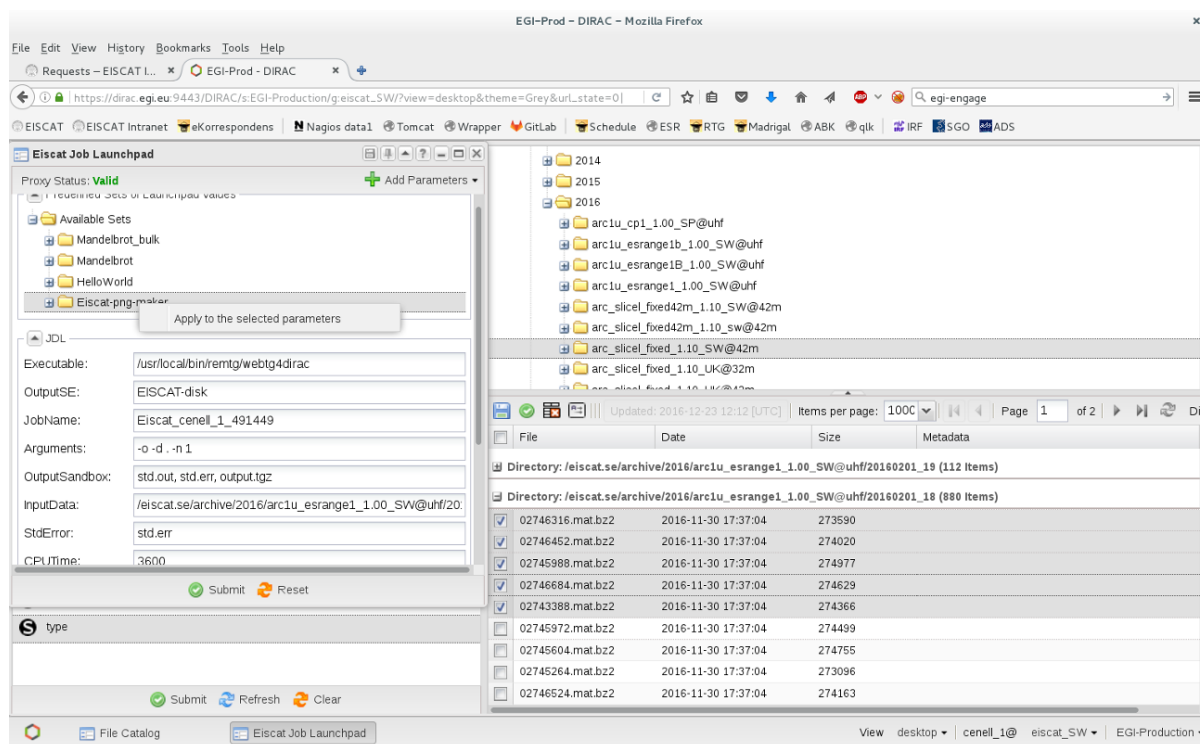

Figure A.11: Submitting a job that will plot the selected EISCAT data files with RTG.

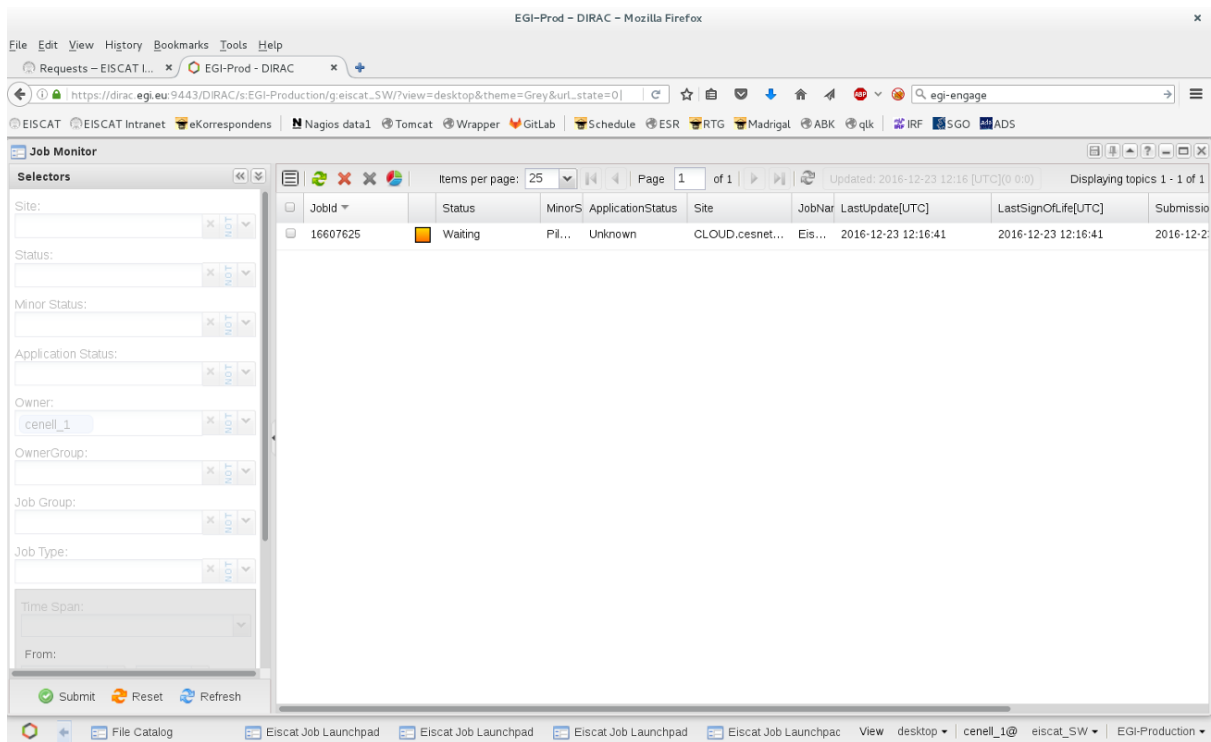

Figure A.12: The DIRAC job monitor showing the status of the submitted job.

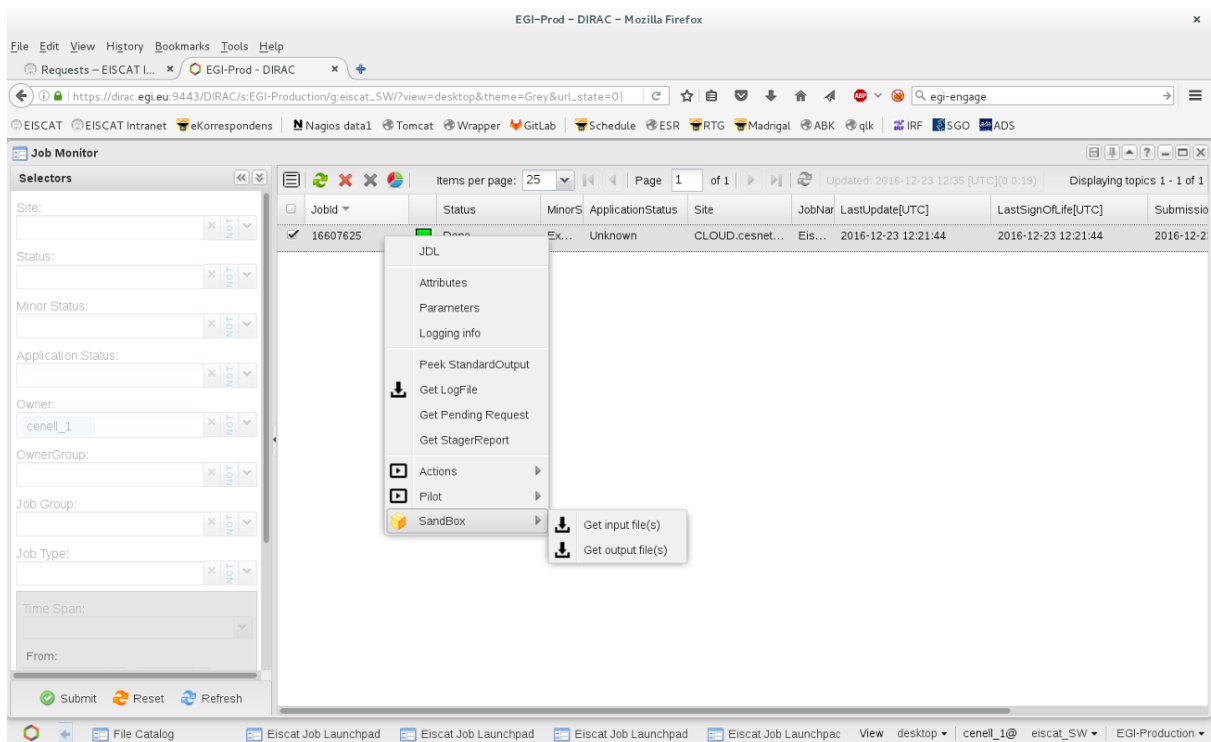

Figure A.13: The sandbox contains the output files for download.

A.6 Feedback

Feedback and bug reports through the EGI RT tracker system will be appreciated. EISCAT portal reports should be submitted through RT queue **direac4egi-eiscat3d-requirements** in EGI RT system: <https://rt.egi.eu/rt/>

Appendix B: EISCAT Portal Administrator Guide

The general DIRAC administrator guide¹¹ is the starting point for all new installs as well as updates of the DIRAC server and the web portal.

The EISCAT prototype portal has modified EISCAT-specific versions of the web GUIs and runs on `dirac.egi.eu` on the dedicated https port 9443.

The EISCAT dedicated instance of the FileCatalog service is set up together with the dedicated MySQL database backend provided by the CYFRONET database servers. It is running at this address using the DIRAC specific client-server protocol:

```
dips://dirac-dms.egi.eu:9187/DataManagement/EiscatFileCatalog
```

The EISCAT specific services are managed and monitored by the standard DIRAC tools. One can use the SystemAdministrator Console to perform basic maintenance operations. The same operations can be performed via the SystemAdministrator application of the general DIRAC web portal.

System Administrator Console

The System Administrator Console (SAC) is the interface which allows a system administrator to connect to any DIRAC server which is running a SystemAdministrator service. This interface allows to perform all the system maintenance tasks remotely.

Starting SAC

The SAC is invoked using `dirac-admin-sysadmin-cli` command for a given DIRAC server, for example:

```
dirac-admin-sysadmin-cli --host <server.address>
```

This starts a special shell with a number of commands defined. There is a help available to see the list of commands and get info about particular commands.

Appendix C: EISCAT-DIRAC software extension

Developers of new DIRAC components can find all the necessary instructions at

¹¹ DIRAC Administrator guide: <http://dirac.readthedocs.io/en/latest/AdministratorGuide/index.html>

<http://dirac.readthedocs.io/en/latest/DeveloperGuide/index.html>

The guide provides coding conventions and examples as well as detailed instructions of the adopted branching model of the DIRAC repositories. The DIRAC software is developed under the Git code management system. The developer guide provides also instructions on how to contribute new codes, describes software revision and release procedures.

Specific EISCAT codes in the DIRAC framework are provided as a DIRAC extension - a standard method for adding community specific codes as a series of plugins. The corresponding EISCAT-DIRAC software project is created in the Github software management service:

<https://github.com/Eiscat3D/EiscatDIRAC>

Currently, plugins are provided for implementation of the EISCAT specific data access policies and for the web GUI.

Definition of the EISCAT-DIRAC extension allows to use standard DIRAC commands (*dirac-distribution*, see the Developer Guide) to manage the extension releases and install them (*dirac-install*) on the DIRAC4EGI servers. The project details are provided in this configuration file:

<https://raw.githubusercontent.com/Eiscat3D/EiscatDIRAC/master/defaults/eiscat.cfg>

The file defines location of the EISCAT-DIRAC software repository as well as the releases repository from where the software will be picked up for the deployment both for the EISCAT specific services and clients.